



Audio Silicon
Specialists™

SSM-2013

VOLTAGE CONTROLLED
AMPLIFIER

SSM Audio Products

DESCRIPTION

The SSM 2013 is a low cost, high performance antilog voltage controlled amplifier with full class A performance. The device has a 94dB signal to noise figure at 0.01% THD. The current inputs and outputs make possible wide bandwidth, easy signal summing, and minimum external component count. Inherently low control feedthrough and 2nd harmonic distortion make trimming unnecessary for most applications.* In addition, the 2013 has more than 12dB of headroom at the rated specifications and can be configured to give up to 40dB of gain.

FEATURES

- 94dB Signal/Noise (20Hz-20kHz)
- 0.01% THD
- 0.03% IMD
- 12dB of Headroom (at rated specs.)
- 800kHz Bandwidth
- Mute and Exponential Control Inputs
- 40dB Gain Capability
- Low Cost
- Full Class A Performance
- Minimum External Component Count
- Current Input, Current Output
- 106dB Dynamic Range (17.5 BITS)
- -30dB Control Feedthrough (untrimmed, RE 0 dBV)
- No Trimming Required for Most Applications

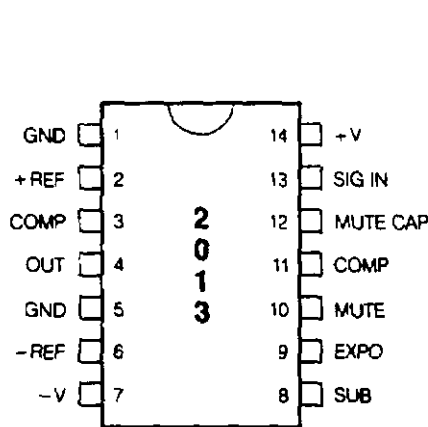

PIN OUT (TOP VIEW)

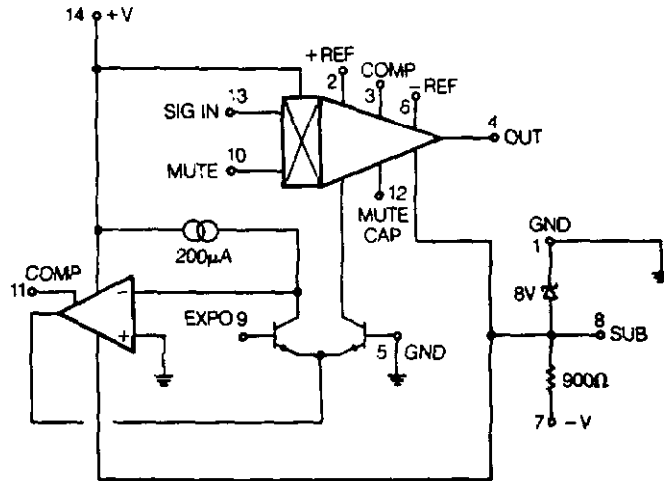

BLOCK DIAGRAM

Revised August 1986



SPECIFICATIONS

OPERATING TEMPERATURE

-10°C to +55°C

STORAGE TEMPERATURE

-55°C to +125°C

Specification* @ $V_s = \pm 15V$ and $T_A = 25^\circ C$

PARAMETER	MIN	TYP	MAX	UNITS	CONDITIONS
Positive Supply Voltage	+12	+15	+18	V	
Negative Supply Voltage ¹	-7.6	-8.2	-8.7	V	
Positive Supply Current	6.5	8.7	11.5	mA	
Negative Supply Current	6.5	8.7	11.5	mA	
Negative Supply Bias Resistor (pin 7 to pin 8)	675	900	1170	Ω	
Expo Input Bias		1.0	2.5	μA	$V_s = GND$
Expo Control Sensitivity		-10		mV/dB	at pin 9
Mute Off (logic low)	0.0V	—	1.0	V	
Mute On (logic high)	3.0V	5	15	V	
Mute Attenuation		-96		dB	(at 1kHz, $V_{PIN10} = +5V$)
Current Gain	0.95	1.0	1.05		$V_s = GND$
Current Output Offset	-7.5	0	+7.5	μA	$V_s = GND$
Output Leakage	-10	0	+10	nA	$V_s = +600mV$
Max Available Output Current	± 1.2			mA	$V_s = GND, 15K$ (pin 3 to -V)
Current Bandwidth (3dB)		800		kHz	$V_s = GND$
Signal Feedthrough		-100		dB	$V_s = +1.2V$
Signal to Noise (20Hz-20kHz) ^{3,4}		-94	92.5	dB	$V_s = GND, No Signal$
THD (untrimmed) ⁴		0.01	0.04	%	$V_s = GND, I_{IN} = 600\mu A_{pp}$
THD (trimmed)		0.004		%	$V_s = GND, I_{IN} = 600\mu A_{pp}$
IMD (untrimmed) ⁴ SMPTE		0.03	0.12	%	$V_s = GND, I_{IN} = 600\mu A_{pp}$
IMD (trimmed) SMPTE		0.012		%	$V_s = GND, I_{IN} = 600\mu A_{pp}$

- 1) Measured at pin 8, pin 7 = -15V.
- 2) V_s is voltage on pin 9.
- 3) Referred to a $400\mu A_{pp}$ input level.
- 4) Parameter is sample tested to max limit (0.4% AQL).

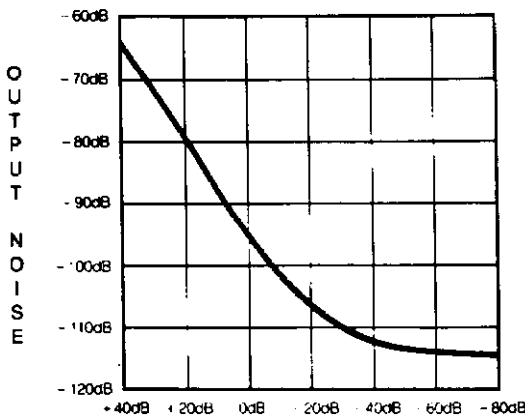

CURRENT GAIN/ATTENUATION
NOISE BANDWIDTH (20Hz-20kHz)
(Referred to $600\mu A_{pp}$ Input Signal
12dB of Headroom)

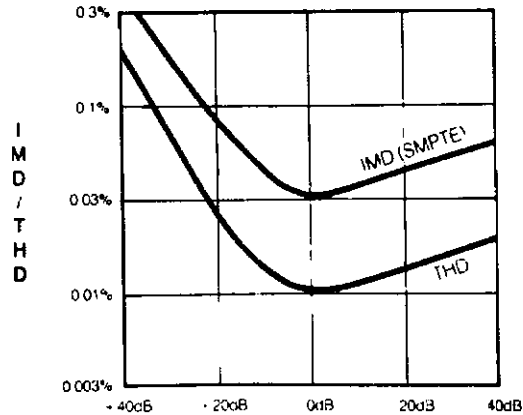

CURRENT GAIN/ATTENUATION (at 12dB Headroom
1kHz (BANDWIDTH 20kHz)
($600\mu A_{pp}$ Constant Output Level) 0dB to +40dB
($600\mu A_{pp}$ Constant Input Level) 0dB to -40dB)

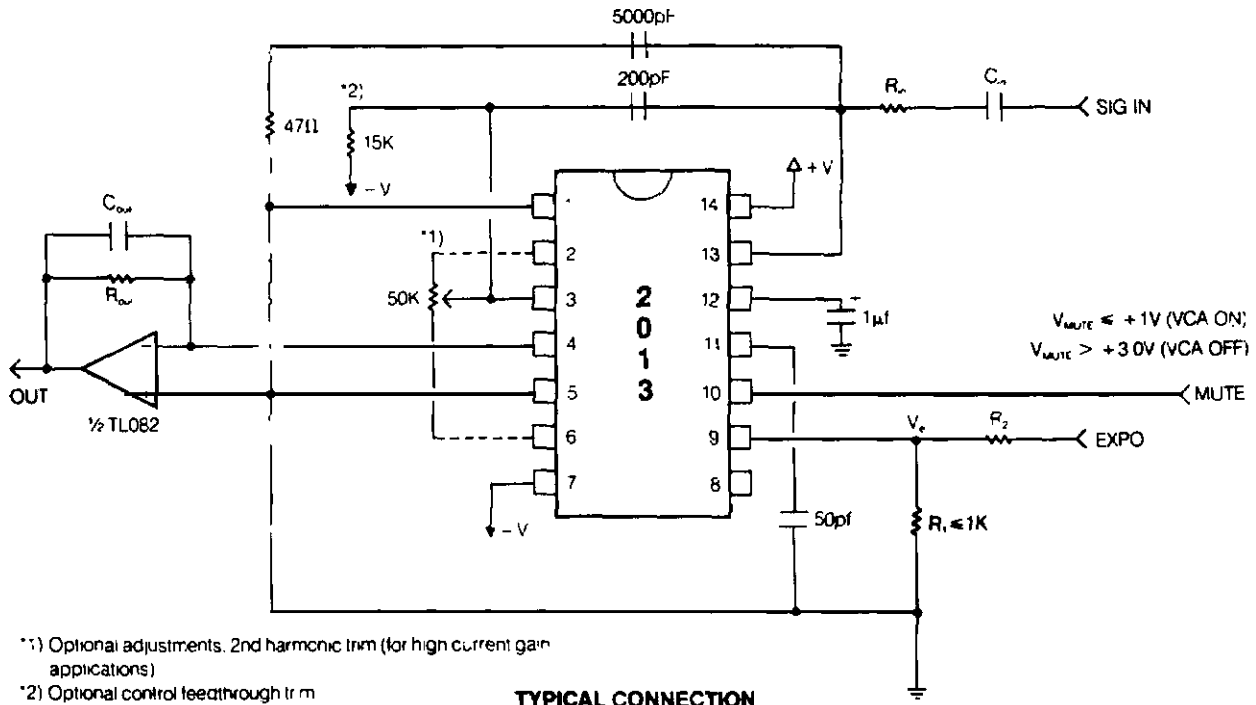

General

The circuit above shows the typical connection of the 2013 as a precision voltage controlled amplifier. When the voltage on pin 9 is ground, the device will be operating at unity current gain.

Signal Input (Pin 13)

Since the 2013 is a current input, current output device, the input and output resistor values can be selected to give optimum performance for any given signal processing environment. A peak to peak input signal of $\pm 300\mu\text{A}$ will give the rated specifications and allow for 12dB of headroom. The device can handle more than $\pm 1.2\text{mA}$ without clipping or other radical increases in distortion. If the average peak input signal is 7V peak to peak and the supplies are $\pm 15\text{V}$, a 12K input resistor will yield the proper input current and headroom.

Frequently 16 to 24dB of headroom is required to handle high crest factor material such as percussive instruments. A $\pm 120\mu\text{A}_{\text{pp}}$ input signal level will allow for 20dB of headroom and yield an 86dB signal to noise ratio at unity gain. The THD and IMD characteristics, given in the graph at the bottom right of page 2, will improve (decrease) by a factor of 2.5.

The input D.C. blocking capacitor is required for best performance so that offsets in previous stages do not upset the balance of the device. C_m should be chosen so that the R_m, C_m combination gives a cutoff frequency below the audio band.

Signal Output (Pin 4)

Since the 2013 is capable of current gain as well as attenuation, several considerations go into the selection of the feedback resistor in the output current to voltage convertor. Distortion will increase significantly when the device is operated above 20 to 30dB of current gain. (See graph at bottom left.) Gain obtained in the output op amp by ratioing the output to input resistors is at the expense of raising the noise floor by the gain factor. If a maximum of 40dB of gain is desired the noise floor would be raised from around -94dB to -54dB referred to a usable input signal level.

A workable compromise in this case would be to allow for 20 to 30dB of current gain in the 2013 and get the rest from the op amp. This will result in a several dB improvement in the noise floor at maximum gain and a significant reduction in distortion.

Noise Measurement

Audio noise in the 2013 cannot be correctly calculated from a broadband noise measurement. This is because the 5000pF-471Ω network at the input form a zero in the compensation network at 600kHz. The noise floor will roll up at the rate of +6dB per octave from about 45kHz to 600kHz where it will again roll off. When measuring audio noise in the 2013 one should limit the bandwidth to 20kHz or 30kHz.

The capacitor in the output current to voltage convertor is needed to insure stability under all signal and output load conditions. A corner frequency of 300kHz will accomplish this but a lower frequency may be desired to limit noise outside the audio band at the expense of a slower transient response.

Mute Control (Pin 10)

The mute circuit in the 2013 allows one to override the dB volume control on pin 9 and to turn the device off or on at a controlled rate. The mute control will respond correctly to the output of most logic families operating from +5V to +15V supplies including TTL and CMOS. The mute cap on pin 12 determines the turn on/turn off rate. This cap and an internal 10K impedance gives a time constant of 10mS with the 1µf cap shown. With this value a transition will be perceived as quick without being too abrupt or "poppy." The impedance at the mute input is nearly infinite below +2V and lowers to about 10K above +3V.

dB/V Control (Pin 9)

The control pin on the 2013 is a high impedance input with an overall control range of +40dB to less than -95dB. The control sensitivity is -1dB/10mV to within ±1.5dB over a ±36dB range. The R₁, R₂ attenuator to pin 9 allows the user to tailor the gain sensitivity of the device to the available control voltage range. (The control sensitivity is -10mV/dB at pin 9. Negative voltages give current gain and positive voltages give attenuation.) If more gain accuracy is required over a wider range and/or if a control summer is required, the circuit in Figure 1 below is recommended.

Trimming (Pins 2, 3, 6, 13)

The 2013 has been designed for minimum distortion, offset and control feedthrough at unity current gain. In order to get optimum performance in applications requiring more than 10 to 20dB of gain, a trim point has been provided. Since distortion in the 2013 is more variable from device to device at high current gain, the trim allows one to get the best overall distortion figures vs. gain on a repeatable basis. The procedure is to apply a control voltage to pin 9 corresponding to the maximum desired current gain and set the input level so that the output is just below clipping. The trim is then adjusted to give minimum distortion.

Control feedthrough in the 2013 can be reduced by using the optional adjustment shown in Figure 2A. The procedure is to apply an A.C. control voltage signal which sweeps from the minimum to maximum desired gain. The signal feeding through to the output is then trimmed to a minimum. The fixed network in Figure 2B can also be use to reduce control feedthrough.

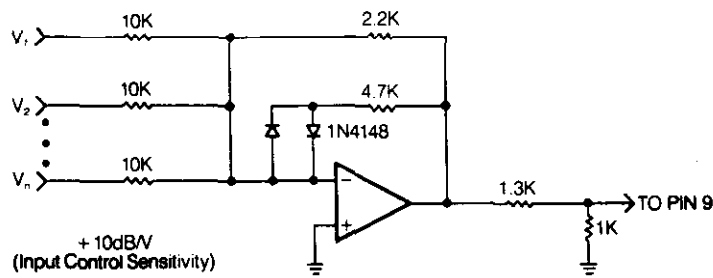

FIGURE 1

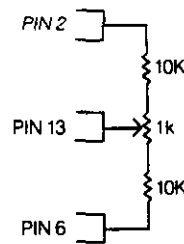

FIGURE 2A

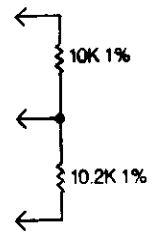

FIGURE 2B