



## PRODUKTINFORMATION

Vi reserverar oss mot fel samt förbehåller oss rätten till ändringar utan föregående meddelande

ELFA artikelnr

73-469-19 NE5517N Transkonduktans OP

73-469-27 NE5517D Transkonduktans OP

## Dual operational transconductance amplifier

NE5517/5517A

## DESCRIPTION

The NE5517 contains two current-controlled transconductance amplifiers, each with a differential input and push-pull output. The NE5517 offers significant design and performance advantages over similar devices for all types of programmable gain applications. Circuit performance is enhanced through the use of linearizing diodes at the inputs which enable a 10dB signal-to-noise improvement referenced to 0.5% THD. The NE5517 is suited for a wide variety of industrial and consumer applications and is recommended as the preferred circuit in the Dolby\* HX (Headroom Extension) system.

Constant impedance buffers on the chip allow general use of the NE5517. These buffers are made of Darlington transistor and a biasing network which changes bias current in dependence of  $I_{ABC}$ .

Therefore, changes of output offset voltages are almost eliminated. This is an advantage of the NE5517 compared to LM13600. With the LM13600, a burst in the bias current  $I_{ABC}$  guides to an audible offset voltage change at the output. With the constant impedance buffers of the NE5517 this effect can be avoided and makes this circuit preferable for high quality audio applications.

## FEATURES

- Constant impedance buffers
- $\Delta V_{BE}$  of buffer is constant with amplifier  $I_{BIAS}$  change
- Pin compatible with LM13600
- Excellent matching between amplifiers
- Linearizing diodes
- High output signal-to-noise ratio

## PIN DESIGNATION

PIN NO.	SYMBOL	NAME AND FUNCTION
1	$I_{ABC}$	Amplifier bias input A
2	D	Diode bias A
3	+IN	Non-inverting input A
4	-IN	Inverting input A
5	$V_O$	Output A
6	$V_-$	Negative supply
7	$I_{N\_BUFFER}$	Buffer input A
8	$V_{O\_BUFFER}$	Buffer output A
9	$V_{O\_BUFFER}$	Buffer output B
10	$I_{N\_BUFFER}$	Buffer input B
11	$V_+$	Positive supply
12	$V_O$	Output B
13	-IN	Inverting input B
14	+IN	Non-inverting input B
15	D	Diode bias B
16	$I_{ABC}$	Amplifier bias input B

## PIN CONFIGURATION

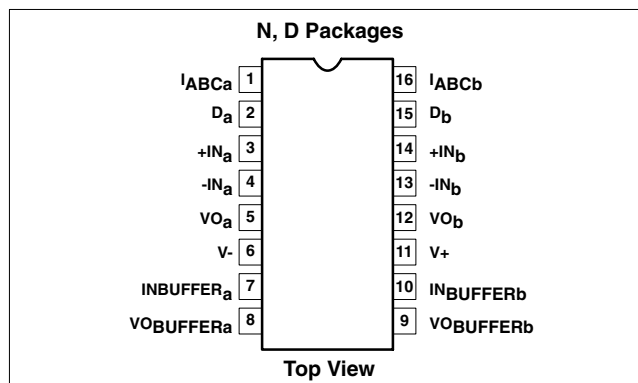

## APPLICATIONS

- Multiplexers
- Timers
- Electronic music synthesizers
- Dolby™ HX Systems
- Current-controlled amplifiers, filters
- Current-controlled oscillators, impedances

Dolby is a registered trademark of Dolby Laboratories Inc., San Francisco, Calif.

# Dual operational transconductance amplifier

NE5517/5517A

## CIRCUIT SCHEMATIC

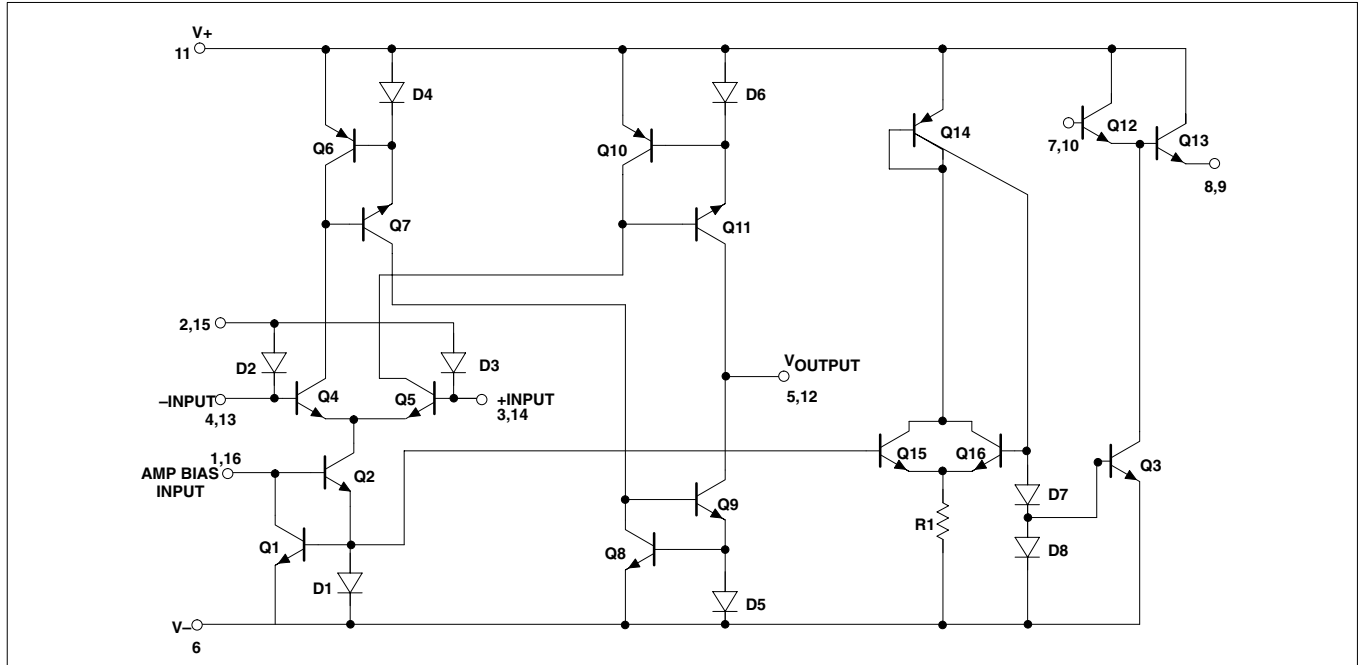

## CONNECTION DIAGRAM

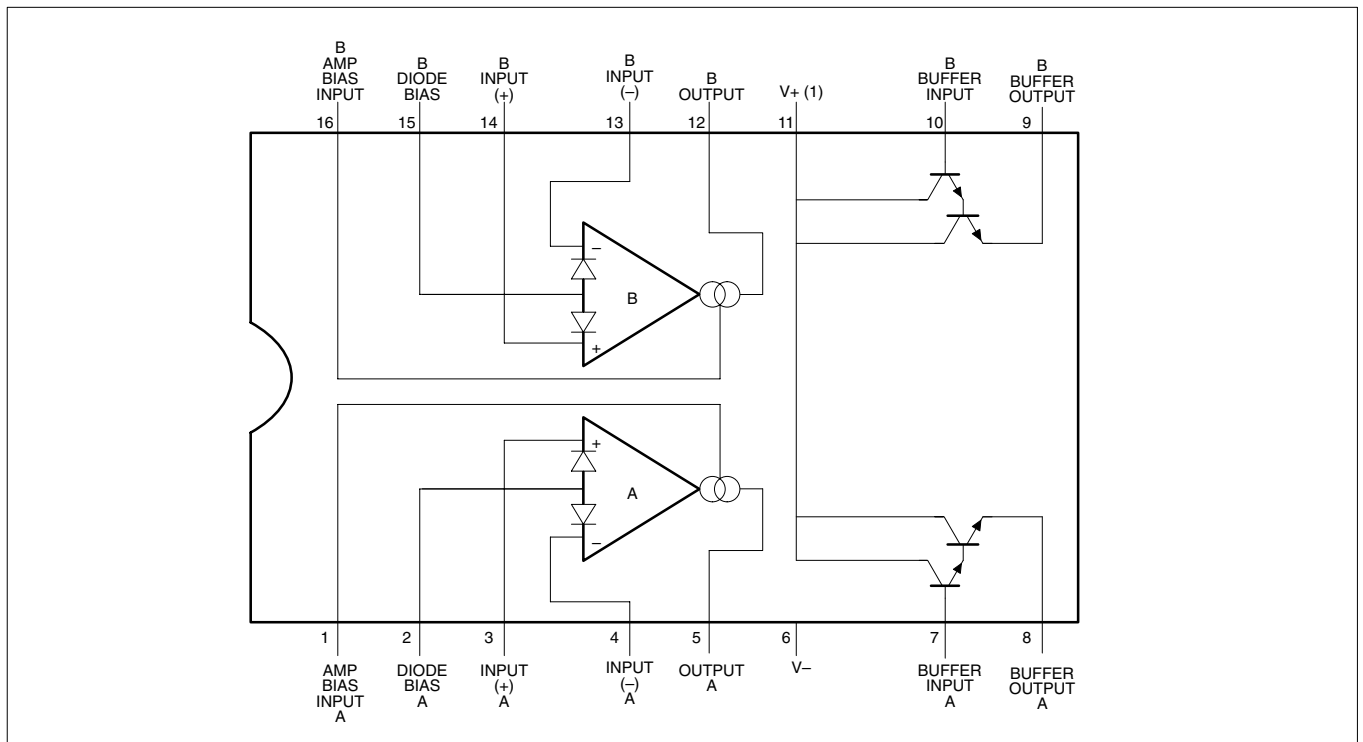

**NOTE:**

1. V+ of output buffers and amplifiers are internally connected.

## Dual operational transconductance amplifier

NE5517/5517A

## ORDERING INFORMATION

DESCRIPTION	TEMPERATURE RANGE	ORDER CODE	DWG #
16-Pin Plastic Dual In-Line Package (DIP)	0 to +70°C	NE5517N	0406C
16-Pin Plastic Dual In-Line Package (DIP)	0 to +70°C	NE5517AN	0406C
16-Pin Small Outline (SO) Package	0 to +70°C	NE5517D	0005D

## ABSOLUTE MAXIMUM RATINGS

SYMBOL	PARAMETER	RATING	UNIT
V <sub>S</sub>	Supply voltage <sup>1</sup>		
	NE5517	36 V <sub>DC</sub> or ±18	V
	NE5517A	44 V <sub>DC</sub> or ±22	V
P <sub>D</sub>	Power dissipation, T <sub>A</sub> =25°C (still air) <sup>2</sup>		
	NE5517N, NE5517AN	1500	mW
	NE5517D	1125	mW
V <sub>IN</sub>	Differential input voltage	±5	V
I <sub>D</sub>	Diode bias current	2	mA
I <sub>ABC</sub>	Amplifier bias current	2	mA
I <sub>SC</sub>	Output short-circuit duration	Indefinite	
I <sub>OUT</sub>	Buffer output current <sup>3</sup>	20	mA
T <sub>A</sub>	Operating temperature range		
	NE5517N, NE5517AN	0°C to +70	°C
V <sub>DC</sub>	DC input voltage	+V <sub>S</sub> to -V <sub>S</sub>	
T <sub>STG</sub>	Storage temperature range	-65°C to +150°C	°C
T <sub>SOLD</sub>	Lead soldering temperature (10sec max)	300	°C

## NOTES:

- For selections to a supply voltage above ±22V, contact factory
- The following derating factors should be applied above 25°C
  - N package at 12.0mW/°C
  - D package at 9.0mW/°C
- Buffer output current should be limited so as to not exceed package dissipation.

DC ELECTRICAL CHARACTERISTICS<sup>1</sup>

SYMBOL	PARAMETER	TEST CONDITIONS	NE5517			NE5517A			UNIT
			Min	Typ	Max	Min	Typ	Max	
V <sub>OS</sub>	Input offset voltage	Over temperature range I <sub>ABC</sub> 5μA		0.4	5		0.4	2	mV
				0.3	5		0.3	5	mV
								2	mV
	ΔV <sub>OS</sub> /ΔT	Avg. TC of input offset voltage		7		7		μV/°C	
	V <sub>OS</sub> including diodes	Diode bias current (I <sub>D</sub> )=500μA		0.5	5		0.5	2	mV
V <sub>OS</sub>	Input offset change	5μA ≤ I <sub>ABC</sub> ≤ 500μA		0.1			0.1	3	mV
I <sub>OS</sub>	Input offset current	Avg. TC of input offset current		0.1	0.6		0.1	0.6	μA
				0.001			0.001		μA/°C
I <sub>BIAS</sub>	Input bias current	Over temperature range		0.4	5		0.4	5	μA
				1	8		1	7	μA
				0.01			0.01		μA/°C
	ΔI <sub>B</sub> /ΔT	Avg. TC of input current		0.01			0.01		μA/°C
g <sub>M</sub>	Forward transconductance	Over temperature range	6700	9600	13000	7700	9600	12000	μmho
			5400			4000			
	g <sub>M</sub> tracking			0.3			0.3		dB
I <sub>OUT</sub>	Peak output current	R <sub>L</sub> =0, I <sub>ABC</sub> =5μA		5		3	5	7	μA
		R <sub>L</sub> =0, I <sub>ABC</sub> =500μA	350	500	650	350	500	650	μA
		R <sub>L</sub> =0,	300			300			μA

## Dual operational transconductance amplifier

NE5517/5517A

DC ELECTRICAL CHARACTERISTICS<sup>1</sup> (continued)

SYMBOL	PARAMETER	TEST CONDITIONS	NE5517			NE5517A			UNIT
			Min	Typ	Max	Min	Typ	Max	
V <sub>OUT</sub>	Peak output voltage								
	Positive	$R_L = \infty, 5\mu A \leq I_{ABC} \leq 500\mu A$	+12	+14.2		+12	+14.2		V
	Negative	$R_L = \infty, 5\mu A \leq I_{ABC} \leq 500\mu A$	-12	-14.4		-12	-14.4		V
I <sub>CC</sub>	Supply current	$I_{ABC} = 500\mu A$ , both channels		2.6	4		2.6	4	mA
	V <sub>OS</sub> sensitivity								
	Positive	$\Delta V_{OS} / \Delta V_+$		20	150		20	150	$\mu V/V$
	Negative	$\Delta V_{OS} / \Delta V_-$		20	150		20	150	$\mu V/V$
CMRR	Common-mode rejection ratio		80	110		80	110		dB
	Common-mode range		$\pm 12$	$\pm 13.5$		$\pm 12$	$\pm 13.5$		V
	Crosstalk	Referred to input <sup>2</sup> 20Hz < f < 20kHz		100			100		dB
I <sub>IN</sub>	Differential input current	$I_{ABC} = 0$ , input = $\pm 4V$		0.02	100		0.02	10	nA
	Leakage current	$I_{ABC} = 0$ (Refer to test circuit)		0.2	100		0.2	5	nA
R <sub>IN</sub>	Input resistance		10	26		10	26		k $\Omega$
B <sub>W</sub>	Open-loop bandwidth			2			2		MHz
SR	Slew rate	Unity gain compensated		50			50		V/ $\mu s$
I <sub>N</sub> BUFFER	Buff. input current	5		0.4	5		0.4	5	$\mu A$
VO-BUFFER	Peak buffer output voltage	5	10			10			V
	$\Delta V_{BE}$ of buffer	Refer to Buffer V <sub>BE</sub> test <sup>3</sup> circuit		0.5	5		0.5	5	mV

## NOTES:

1. These specifications apply for  $V_S = \pm 15V$ ,  $T_A = 25^\circ C$ , amplifier bias current ( $I_{ABC}$ ) = 500 $\mu A$ , Pins 2 and 15 open unless otherwise specified. The inputs to the buffers are grounded and outputs are open.
2. These specifications apply for  $V_S = \pm 15V$ ,  $I_{ABC} = 500\mu A$ ,  $R_{OUT} = 5k\Omega$  connected from the buffer output to  $-V_S$  and the input of the buffer is connected to the transconductance amplifier output.
3.  $V_S = \pm 15$ ,  $R_{OUT} = 5k\Omega$  connected from Buffer output to  $-V_S$  and  $5\mu A \leq I_{ABC} \leq 500\mu A$ .

# Dual operational transconductance amplifier

## NE5517/5517A

### TYPICAL PERFORMANCE CHARACTERISTICS

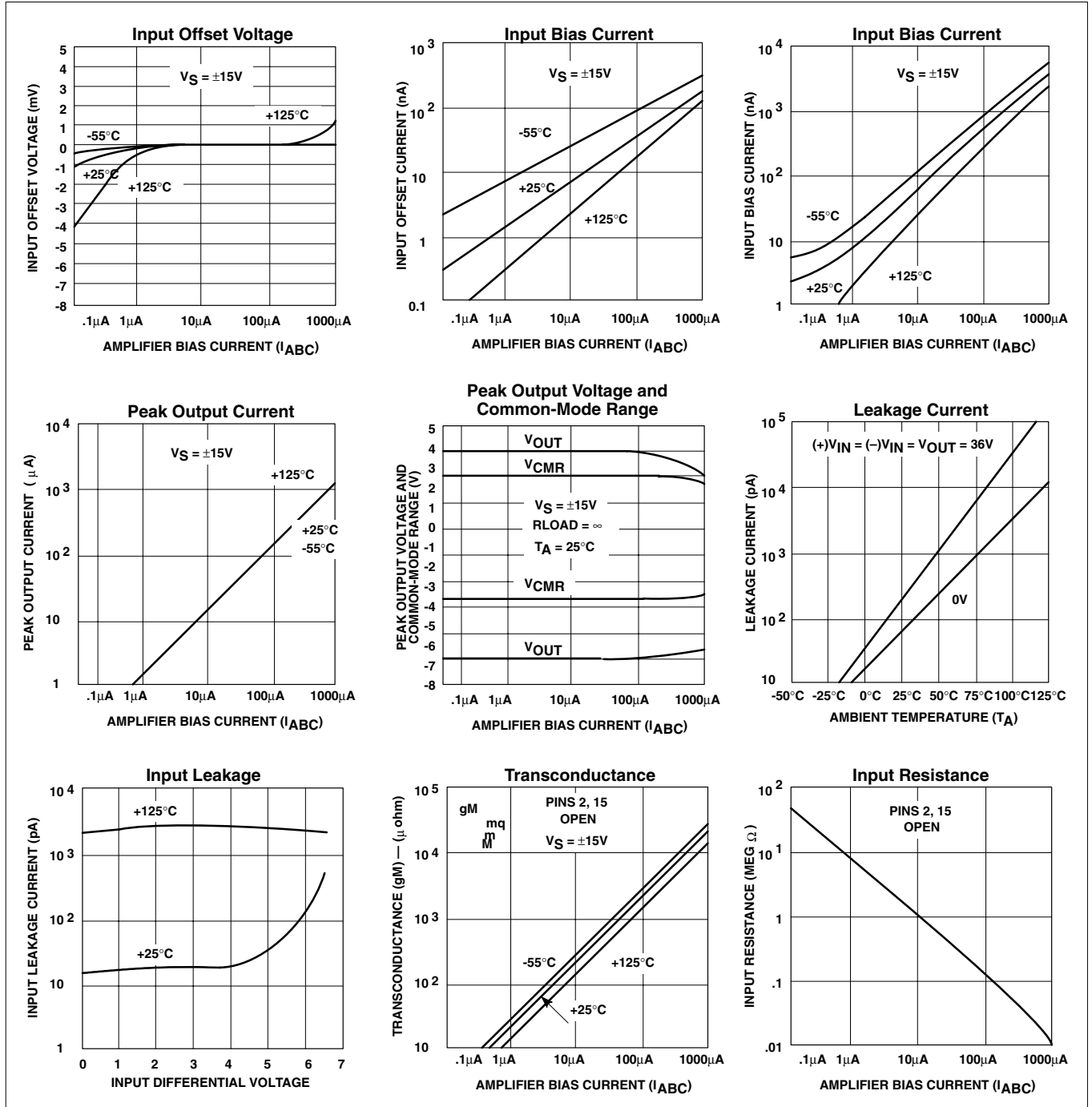

# Dual operational transconductance amplifier

NE5517/5517A

## TYPICAL PERFORMANCE CHARACTERISTICS (Continued)

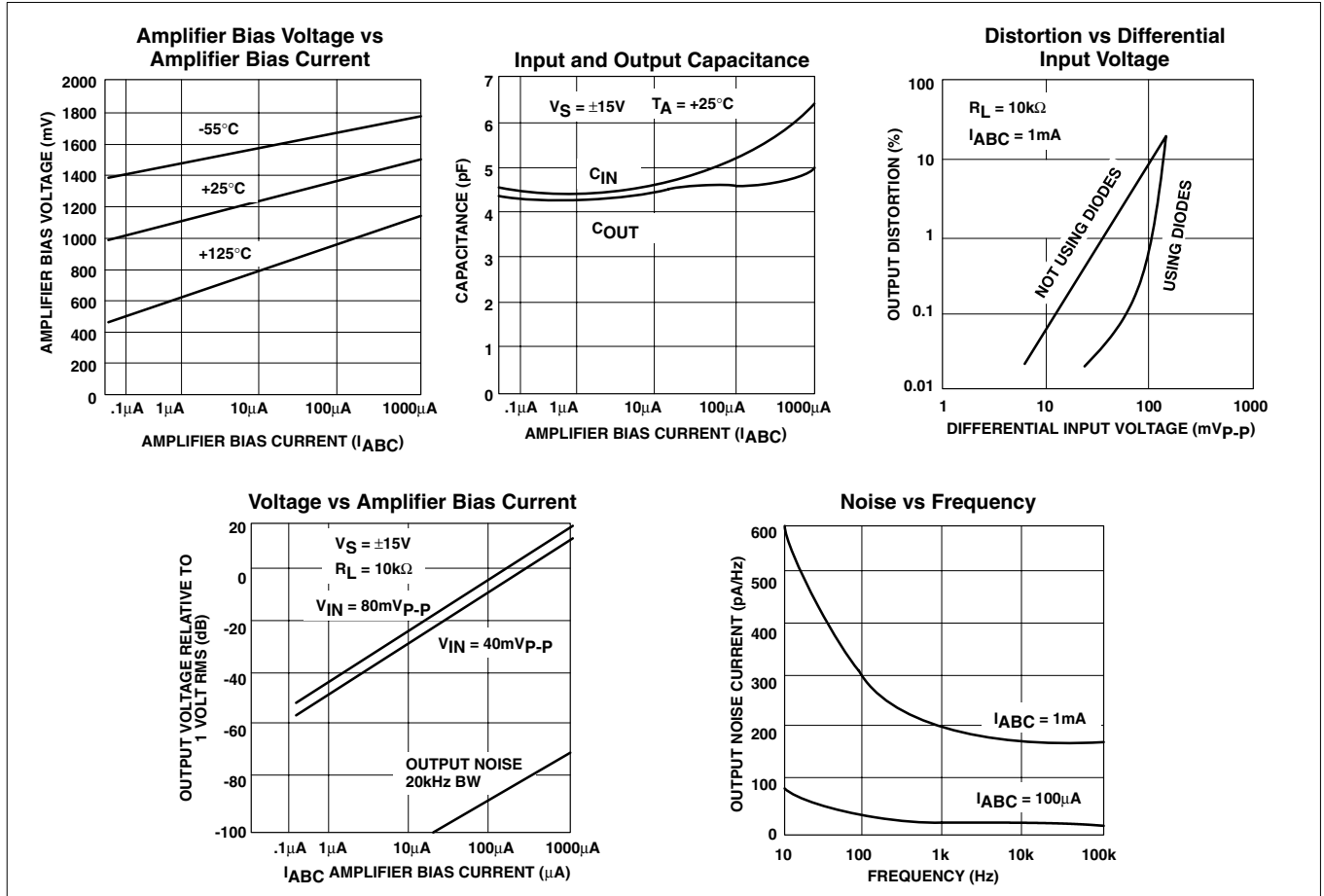

# Dual operational transconductance amplifier

# NE5517/5517A

## TYPICAL PERFORMANCE CHARACTERISTICS (Continued)

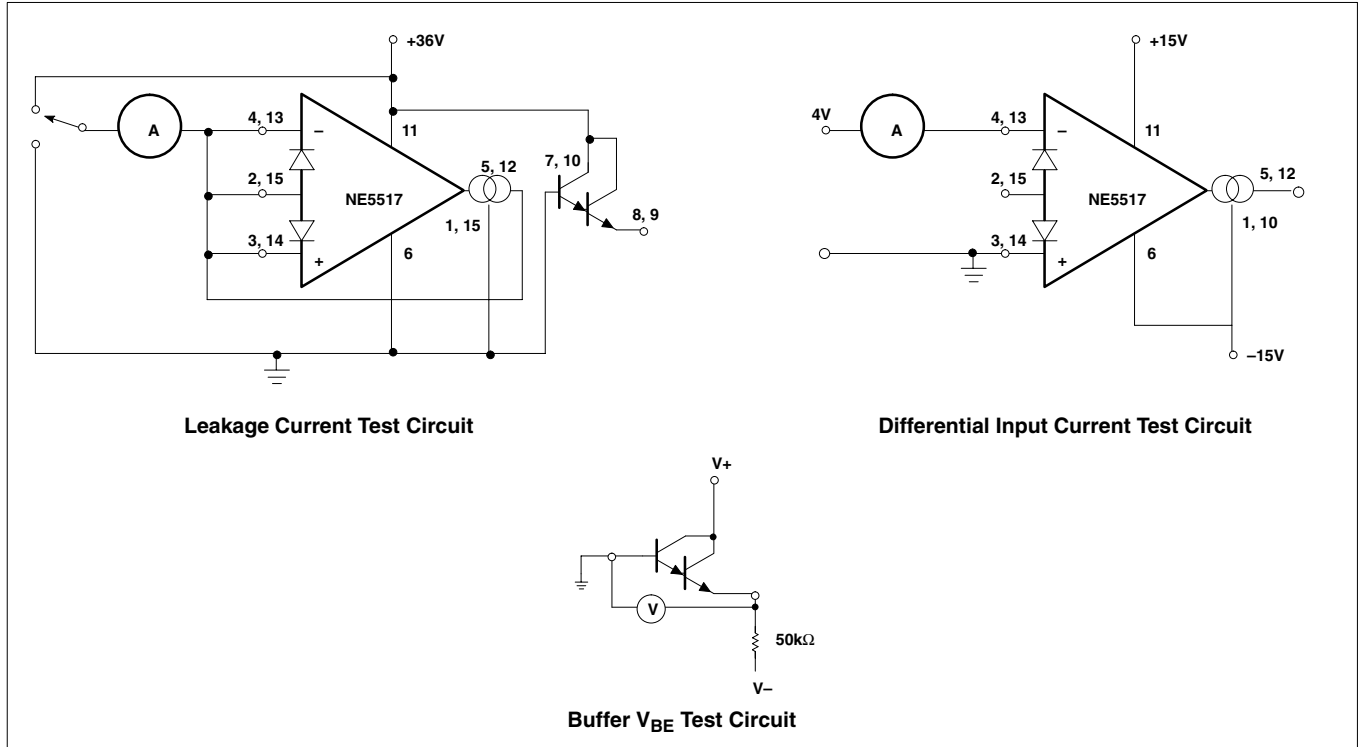

## APPLICATIONS

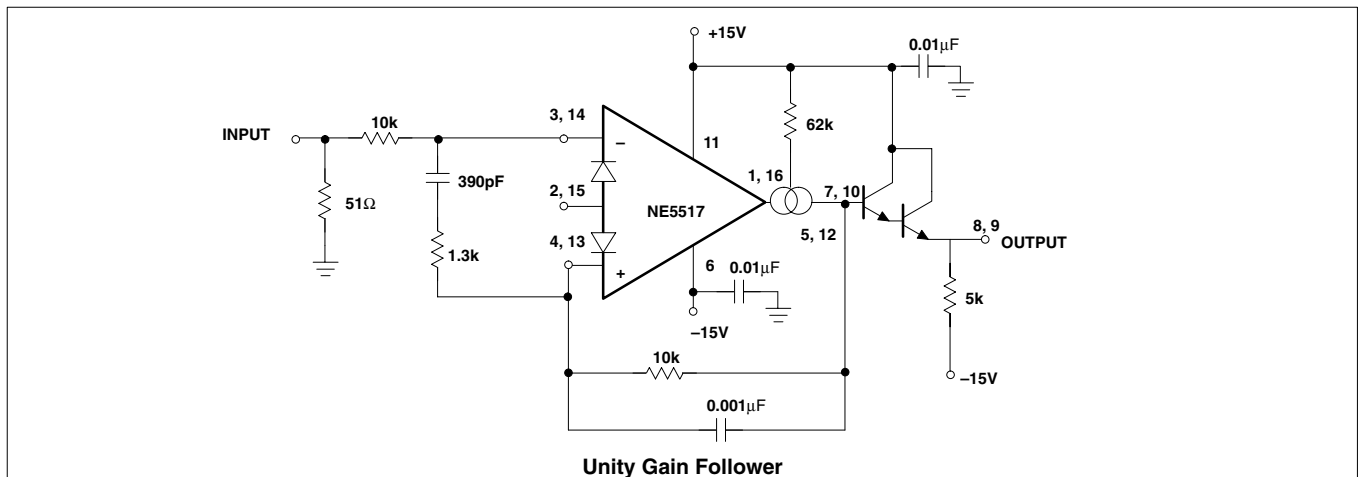

### CIRCUIT DESCRIPTION

The circuit schematic diagram of one-half of the NE5517, a dual operational transconductance amplifier with linearizing diodes and impedance buffers, is shown in Figure 1.

#### 1. Transconductance Amplifier

The transistor pair, Q<sub>4</sub> and Q<sub>5</sub>, forms a transconductance stage. The ratio of their collector currents (I<sub>4</sub> and I<sub>5</sub>, respectively) is defined by the differential input voltage, V<sub>IN</sub>, which is shown in equation 1.

$$V_{IN} = \frac{KT}{q} \ln \frac{I_5}{I_4} \quad (1)$$

Where V<sub>IN</sub> is the difference of the two input voltages

$$KT \cong 26\text{mV at room temperature (300}^\circ\text{k).$$

Transistors Q<sub>1</sub>, Q<sub>2</sub> and diode D<sub>1</sub> form a current mirror which focuses the sum of current I<sub>4</sub> and I<sub>5</sub> to be equal to amplifier bias current I<sub>B</sub>:

$$I_4 + I_5 = I_B \quad (2)$$

If V<sub>IN</sub> is small, the ratio of I<sub>5</sub> and I<sub>4</sub> will approach unity and the Taylor series of ln function can be approximated as

$$\frac{KT}{q} \ln \frac{I_5}{I_4} \approx \frac{KT}{q} \frac{I_5 - I_4}{I_4} \quad (3)$$



# Dual operational transconductance amplifier

# NE5517/5517A

and  $I_4 \cong I_5 \cong I_B$

$$\frac{KT}{q} \ln \frac{I_5}{I_4} \approx \frac{KT}{q} \frac{I_5 - I_4}{2I_B} = \frac{2KT}{q} \frac{I_5 - I_4}{I_B} = V_{IN} \quad (4)$$

$$I_5 - I_4 = V_{IN} \frac{I_B}{2KT}$$

The remaining transistors (Q6 to Q11) and diodes (D4 to D6) form three current mirrors that produce an output current equal to  $I_5$  minus  $I_4$ . Thus:

$$V_{IN} I_B \frac{q}{2KT} = I_O \quad (5)$$

The term  $\frac{I_B}{2KT}$  is then the transconductance

of the amplifier and is proportional to  $I_B$ .

## 2. Linearizing Diodes

For  $V_{IN}$  greater than a few millivolts, equation 3 becomes invalid and the transconductance increases non-linearly. Figure 2 shows how the internal diodes can linearize the transfer function of the operational amplifier. Assume D2 and D3 are biased with current sources and the input signal current is  $I_S$ . Since

$I_4 + I_5 = I_B$  and  $I_5 - I_4 = I_O$ , that is:

$$I_4 = (I_B - I_O), I_5 = (I_B + I_O)$$

For the diodes and the input transistors that have identical geometries and are subject to similar voltages and temperatures, the following equation is true:

$$\frac{T}{q} \ln \frac{\frac{I_D}{2} I_S}{\frac{I_D}{2} - I_S} = \frac{KT}{q} \ln \frac{1 + 2(I_B - I_O)}{1 + 2(I_B + I_O)} \quad (6)$$

$$I_O = I_S \frac{2I_B}{I_D} \text{ for } |I_S| \frac{I_D}{2}$$

The only limitation is that the signal current should not exceed  $I_D$ .

## 3. Impedance Buffer

The upper limit of transconductance is defined by the maximum value of  $I_B$  (2mA). The lowest value of  $I_B$  for which the amplifier will function therefore determines the overall dynamic range. At low values of  $I_B$ , a buffer with very low input bias current is desired. A Darlington amplifier with constant-current source (Q14, Q15, Q16, D7, D8, and R1) suits the need.

## APPLICATIONS

### Voltage-Controlled Amplifier

In Figure 3, the voltage divider R2, R3 divides the input-voltage into small values (mV range) so the amplifier operates in a linear manner.

It is:

$$I_{OUT} = -V_{IN} \frac{R_3}{R_2 R_3} g_M;$$

$$V_{OUT} = I_{OUT} R_L;$$

$$A = \frac{V_{OUT}}{V_{IN}} = \frac{R_3}{R_2 R_3} g_M R_L$$

$$(3) g_M = 19.2 I_{ABC}$$

( $g_M$  in  $\mu\text{mhos}$  for  $I_{ABC}$  in mA)

Since  $g_M$  is directly proportional to  $I_{ABC}$ , the amplification is controlled by the voltage  $V_C$  in a simple way.

When  $V_C$  is taken relative to  $-V_{CC}$  the following formula is valid:

$$I_{ABC} = \frac{(V_C - 1.2V)}{R_1}$$

The 1.2V is the voltage across two base-emitter baths in the current mirrors. This circuit is the base for many applications of the NE5517.

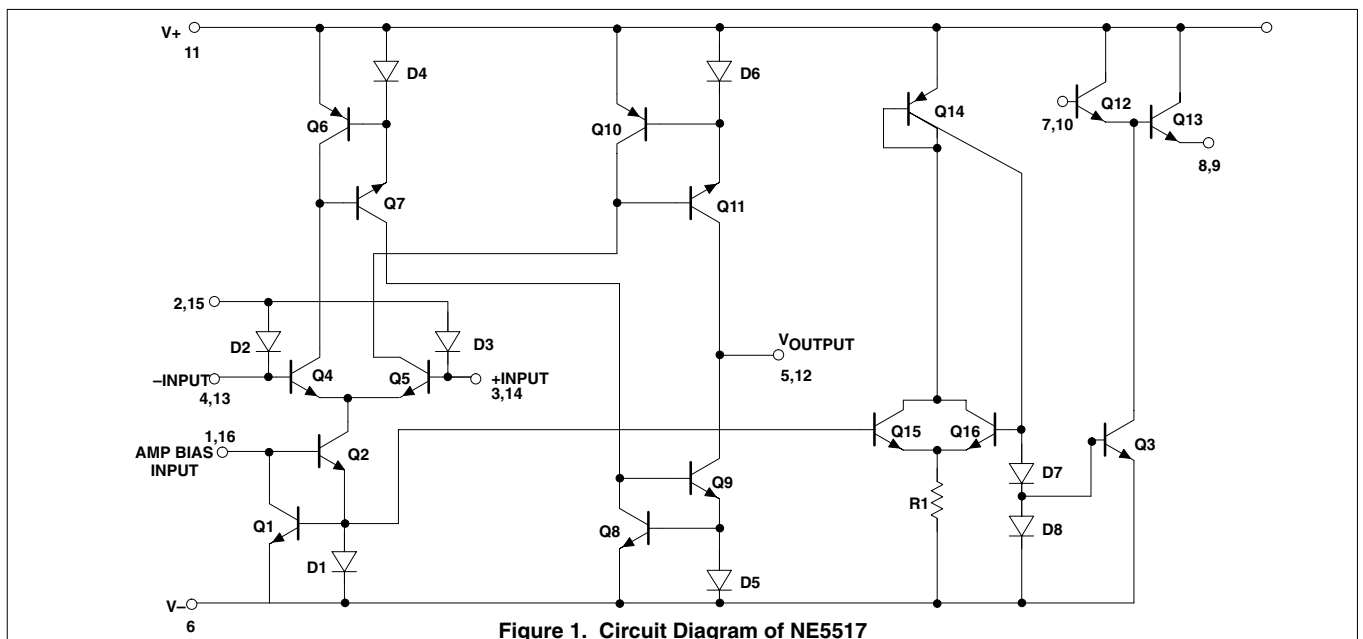

Figure 1. Circuit Diagram of NE5517

# Dual operational transconductance amplifier

# NE5517/5517A

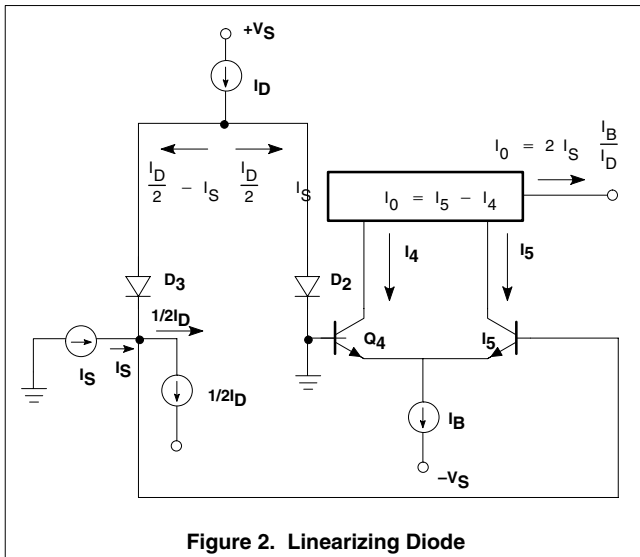

Figure 2. Linearizing Diode

### Stereo Amplifier With Gain Control

Figure 4 shows a stereo amplifier with variable gain via a control input. Excellent tracking of typical 0.3dB is easy to achieve. With the potentiometer,  $R_P$ , the offset can be adjusted. For AC-coupled amplifiers, the potentiometer may be replaced with two 510Ω resistors.

### Modulators

Because the transconductance of an OTA (Operational Transconductance Amplifier) is directly proportional to  $I_{ABC}$ , the amplification of a signal can be controlled easily. The output current is the product from transconductance  $\times$  input voltage. The circuit is effective up to approximately 200kHz. Modulation of 99% is easy to achieve.

### Voltage-Controlled Resistor (VCR)

Because an OTA is capable of producing an output current proportional to the input voltage, a voltage variable resistor can be made. Figure 6 shows how this is done. A voltage presented at the  $R_X$  terminals forces a voltage at the input. This voltage is multiplied by  $g_M$  and thereby forces a current through the  $R_X$  terminals:

$$R_X = \frac{R}{g_M} \frac{R_A}{R_A}$$

where  $g_M$  is approximately 19.21  $\mu$ MHOs at room temperature. Figure 7 shows a Voltage Controlled Resistor using linearizing diodes. This improves the noise performance of the resistor.

### Voltage-Controlled Filters

Figure 8 shows a Voltage Controlled Low-Pass Filter. The circuit is a unity gain buffer until  $X_C/g_M$  is equal to  $R/R_A$ . Then, the frequency response rolls off at a 6dB per octave with the -3dB point being defined by the given equations. Operating in the same manner, a Voltage Controlled High-Pass Filter is shown in Figure 9. Higher order filters can be made using additional amplifiers as shown in Figures 10 and 11.

### Voltage-Controlled Oscillators

Figure 12 shows a voltage-controlled triangle-square wave generator. With the indicated values a range from 2Hz to 200kHz is possible by varying  $I_{ABC}$  from 1mA to 10 $\mu$ A.

The output amplitude is determined by  $I_{OUT} \times R_{OUT}$ .

Please notice the differential input voltage is not allowed to be above 5V.

With a slight modification of this circuit you can get the sawtooth pulse generator, as shown in Figure 13.

### APPLICATION HINTS

To hold the transconductance  $g_M$  within the linear range,  $I_{ABC}$  should be chosen not greater than 1mA. The current mirror ratio should be as accurate as possible over the entire current range. A current mirror with only two transistors is not recommended. A suitable current mirror can be built with a PNP transistor array which causes excellent matching and thermal coupling among the transistors. The output current range of the DAC normally reaches from 0 to -2mA. In this application, however, the current range is set through  $R_{REF}$  (10kΩ) to 0 to -1mA.

$$I_{DACMAX} = 2 \frac{V_{REF}}{R_{REF}} = 2 \frac{5V}{10k} = 1mA$$

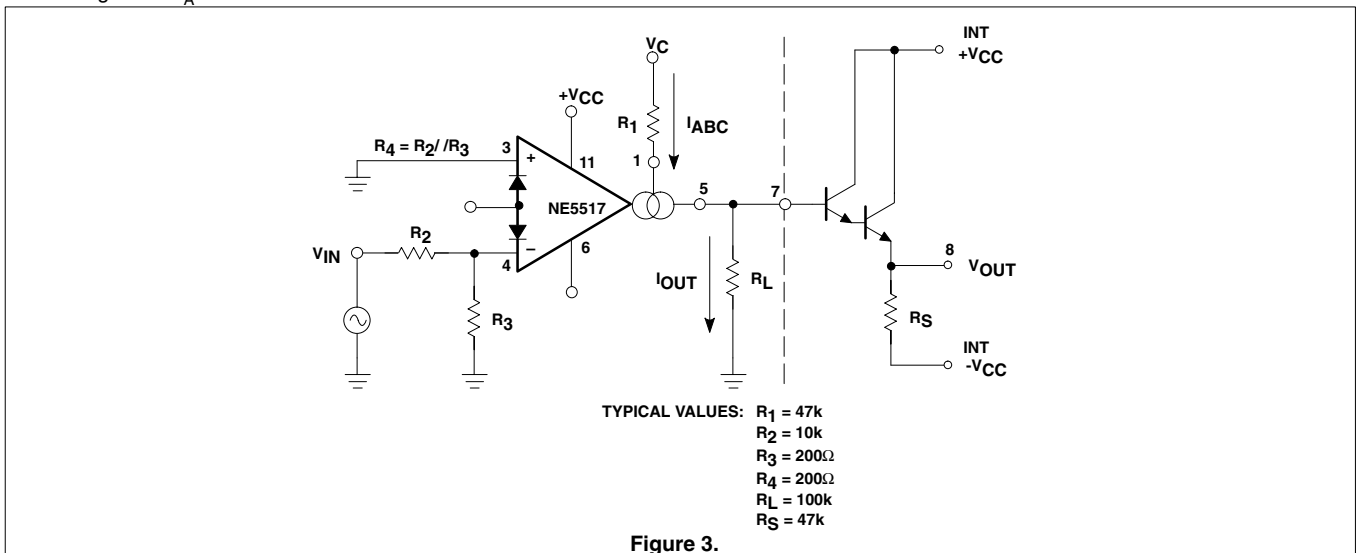

Figure 3.

# Dual operational transconductance amplifier

# NE5517/5517A

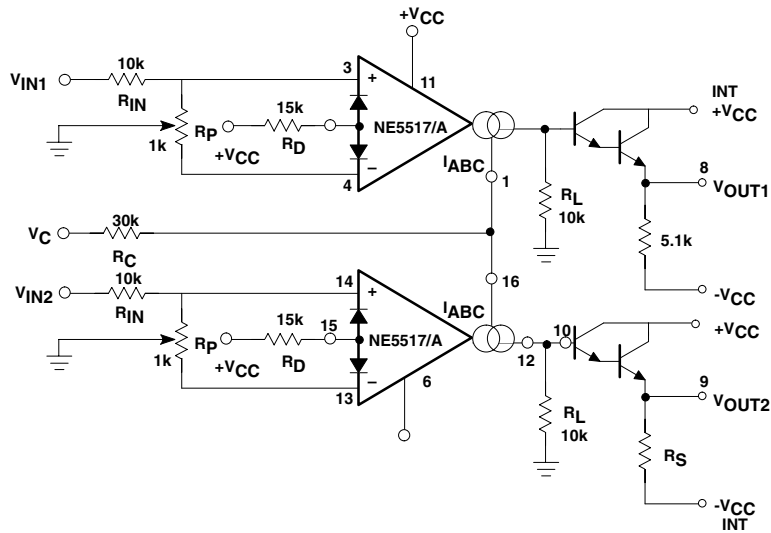

Figure 4. Gain-Controlled Stereo Amplifier

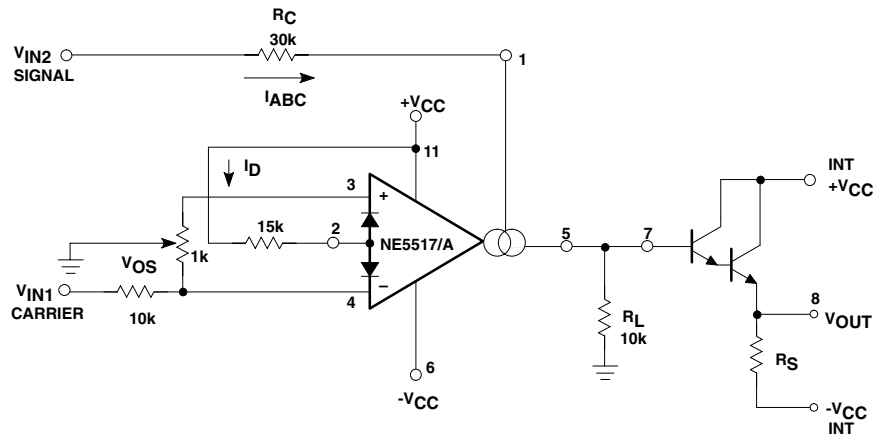

Figure 5. Amplitude Modulator

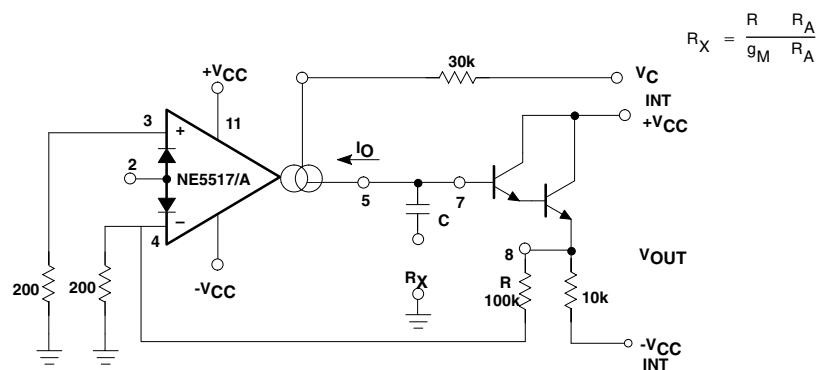

Figure 6. VCR

# Dual operational transconductance amplifier

# NE5517/5517A

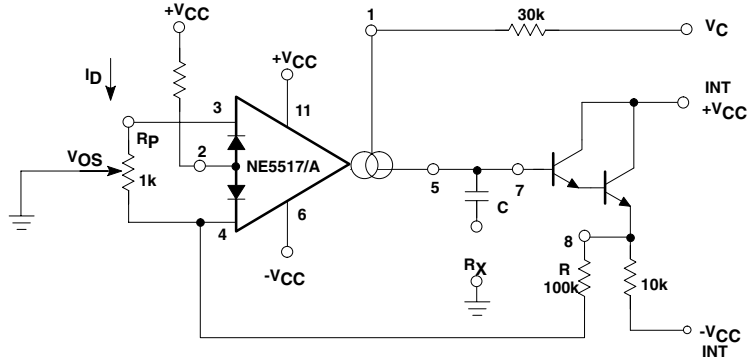
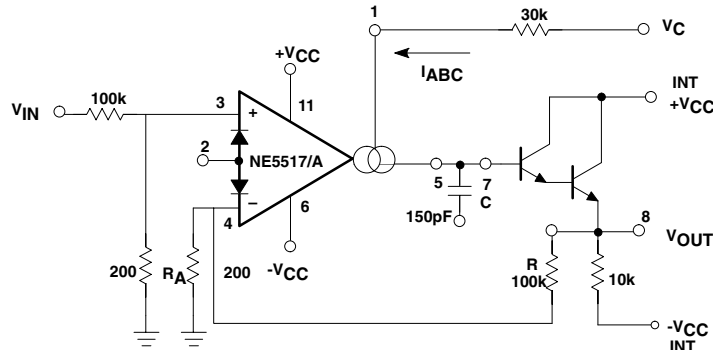

Figure 7. VCR with Linearizing Diodes



NOTE:

$$f_O = \frac{R_A g_M}{g(R + R_A) 2\pi C}$$

Figure 8. Voltage-Controlled Low-Pass Filter

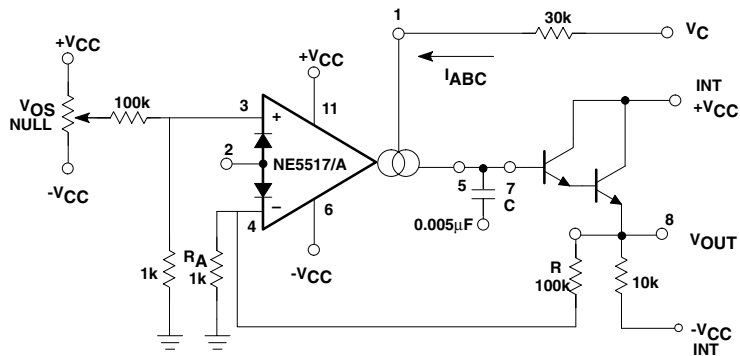

NOTE:

$$f_O = \frac{R_A g_M}{g(R + R_A) 2\pi C}$$

Figure 9. Voltage-Controlled High-Pass Filter

# Dual operational transconductance amplifier

# NE5517/5517A

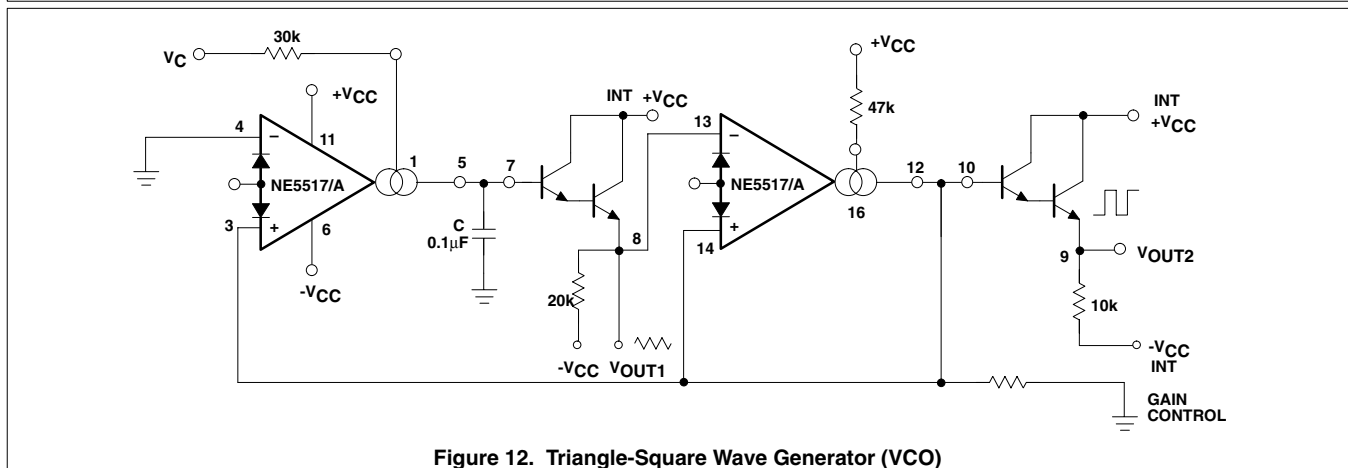
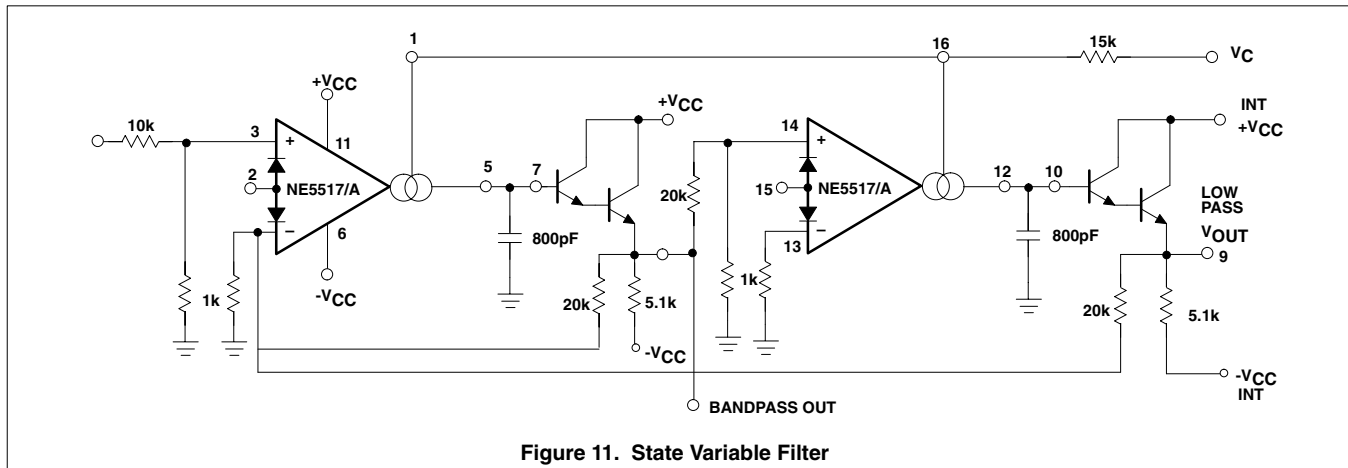
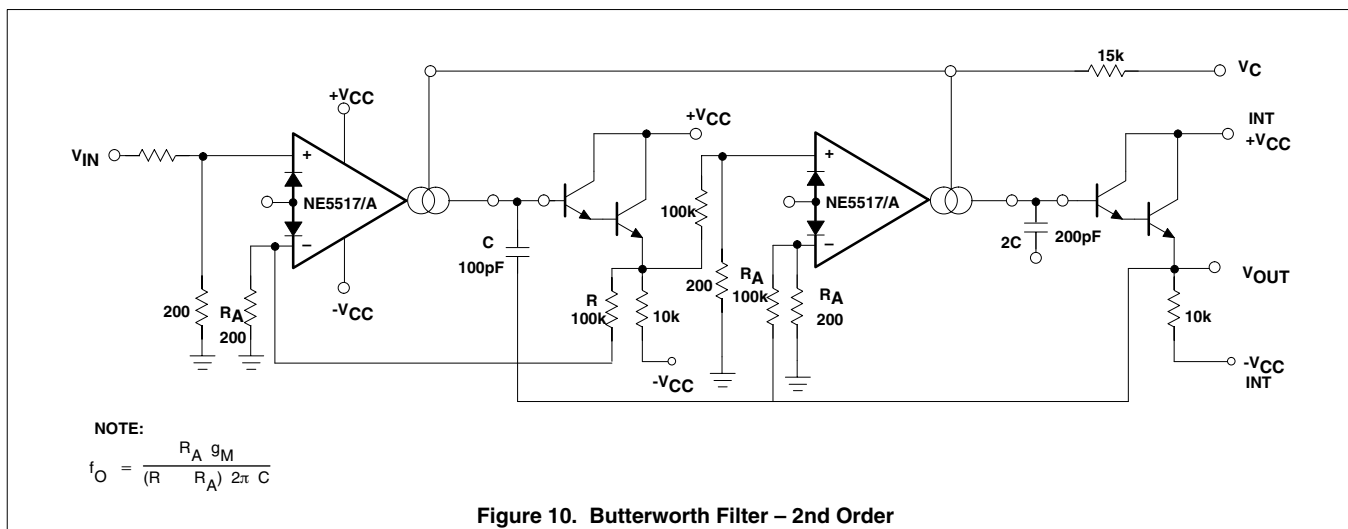

Dual operational transconductance amplifier

NE5517/5517A

