

Percussion Synthesizer Kit PCK-100

AMDEK ASSEMBLY MANUAL

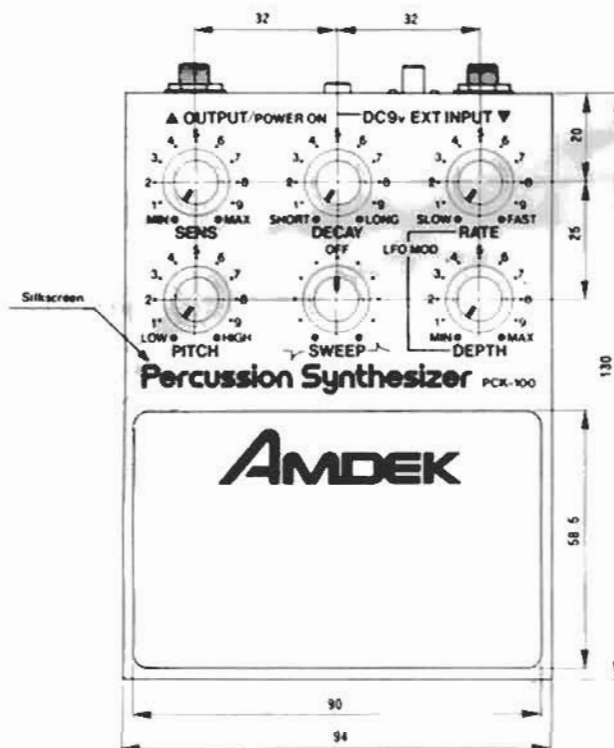

- Your kit is one of a range of AMDEK products. Like all AMDEK Instruments it incorporates carefully selected components which have been subjected to rigorous factory testing and inspection. This ensures a high quality level to back up this original concept. Before starting assembly of your kit, however, be sure to read the instructions in correct sequence. This will ensure that you will get the maximum benefit from your PCK-100.

AMDEK Corporation

Assembly Tools

- **Soldering Iron:** Use a 15–30W fine tip iron. Have ready a wet pad or cloth for cleaning the tip.
- **Cutter and strippers:** For cutting wire and stripping vinyl insulation. Use side cutters with a hole in the cutting edge (for stripping). If possible a wire stripper, specifically for this purpose should be purchased.
- **Pliers:** Round nose with sidecutter.
- **Screw Drivers:** 1 Cross ressed head (with fine tip)
1 Cross ressed head (suitable for M3 screws)

You will also need a 006P 9V Battery (This is not supplied with the kit, to avoid corrosion problems).

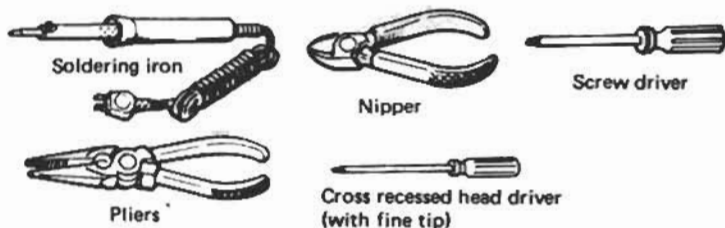

Assembly Notes

- The printed circuit board (P.C.B.) contained here has been carefully factory checked for full function. So, if all the steps outlined are followed, the assembled unit should work as intended.
- The most important work is soldering—90% of assembly failures come from this source. Use the solder supplied in the kit. Do not use soldering paste in any part of the assembly. Never touch a heated soldering iron tip to a joint for an extended time since it could result in damage to the components. Solder as quickly and precisely as possible.



1 Wrap wire round terminal to be soldered

2 Apply heated iron to wire and terminal. Then melt solder into the joint.

3 When solder has flowed into the joint remove the iron tip and hold the wire steady for a moment. If the solder is smooth and bright, over all of the joint, the work is good. When cool, check by gently pulling on the wire.

Parts List

- Unpack and check the contents of the kit against the Drawings.
- Tick each box as the part is identified, then return it to the package.



Scale



Assembly Steps

Check in each step before proceeding to the next.

1. Turn on power supply to the soldering iron.
2. Solder the lead wires to control pots 4 x 100KΩA, 1 x 100ΩA and, 1KΩB (with center tap). Cut the lead wires to the lengths specified. Strip the wire insulation with side cutters 6mm from one end and 3mm from the other; take care not to damage the core strands.

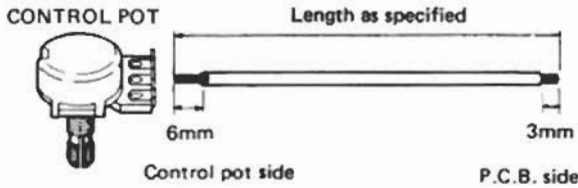

* How to strip the vinyl insulation:

Place the vinyl wire in the hole of the cutters or stripper, to grip the desired length to be removed. Pull the tool sideways. Take care not to damage the core strands.



* How to Tin the wire:

Twist the core strands slightly, flow solder over the wire to make the surface wet with solder, so that a thin coating forms over all the strands. This "tinning" process will help to make subsequent solder works easier.

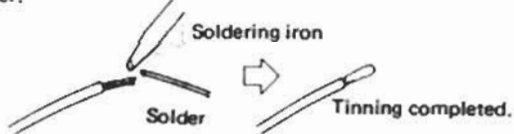

2.-1

Wiring to RATE control

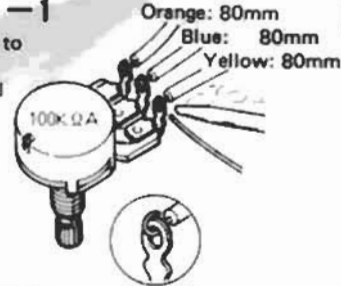

An adequate amount of solder will be that which is just enough to fill the hole.

Wrap lead wire around the terminal as shown, then solder the joint.

2.-2

Wiring to PITCH control

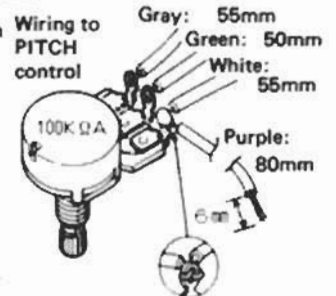

Wrap both wires around the terminal as shown then solder the joint.

2.-5

Wiring to DECAY control
Leave this terminal blank

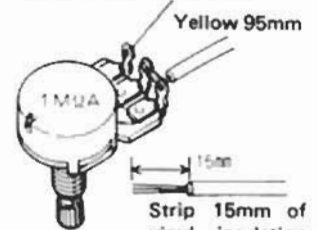

Strip 15mm of vinyl insulation from one end of the yellow wire then wrap around both center and outer terminals as shown.

2.-3

Wiring to DEPTH control

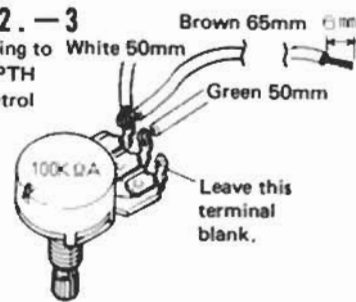

2.-4

Wiring to SENS control

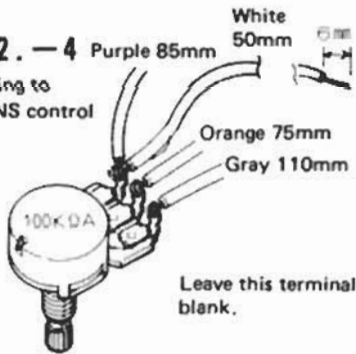

2.-6

Wiring to SWEEP control

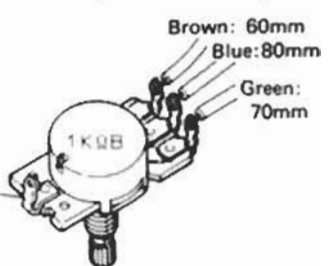

3. Cut the battery snap lead wire to 80mm. Strip 3mm of vinyl insulation from them, then tin the core strands.

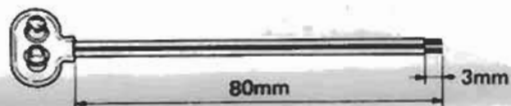

4. Cut the piezoelectric pickup lead wires to 85mm. Strip 6mm of vinyl insulation from one wire, and 3mm from the other (It doesn't matter which one you select), then tin the core strands.

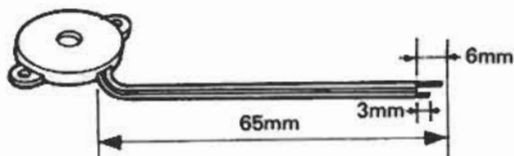

5. On the P.W.B. there are eyelet holes numbered from 1 to 18. (on the component mounting side, fill up the holes with molten solder in preparation for the following soldering steps.)

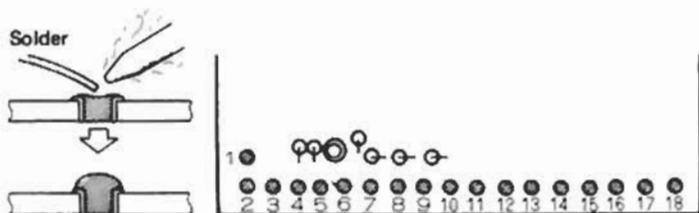

* Pay extreme care, not to touch any adjacent parts with the heated soldering iron.

6. Solder the lead wires to the P.C.B. No further solder application is required since the eyelets have enough solder from the previous step.

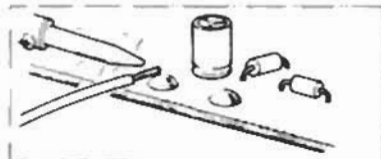

* Position the lead wire and apply the heated soldering iron tip from upper side. Remove iron when solder melts, hold wire in place for a few moments to allow solder solidify.

Wiring Diagram for Soldering to P.C. board

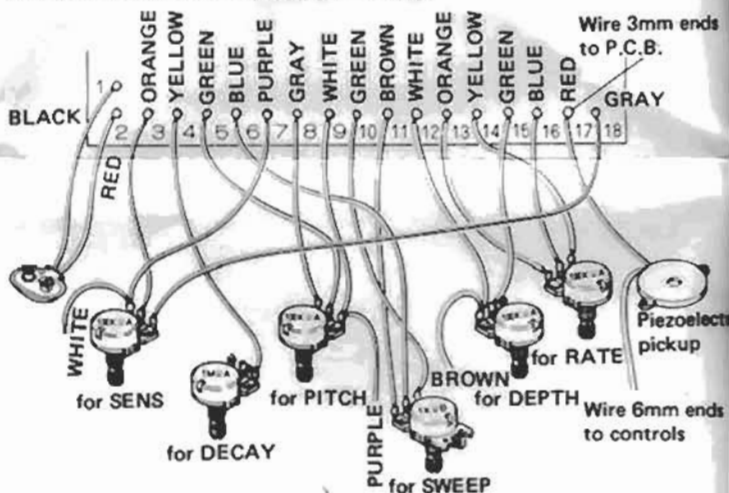

Lead wire from	Connection to
Battery Snap ConnectorBLK → ① RED → ②
SENS Control 100KΩAORN → ③ PRP → ⑦ GRA → ⑮
DECAY Control 1MΩAYEL → ④
PITCH Control 100KΩAGRN → ⑤ GRA → ⑧ WHT → ⑨
SWEEP Control 1KΩBBLU → ⑥ GRN → ⑩ BRN → ⑪
DEPTH Control 100KΩAORA → ⑬ YEL → ⑭ BLU → ⑯
Piezoelectric PickupRED (3mm stripped end) → ⑰

Refer to the Diagram. Be careful not to make misconnections. With a red pencil or the like, check completion of soldering wire by wire, to make doubly.

7. Solder the remaining wires, connecting controls and pick up as illustrated.

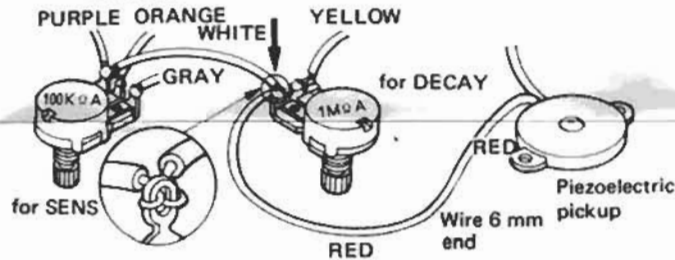

Solder to the blank terminal of DECAY control (1MΩA) both the WHITE lead from SENS control (100KΩA) and the RED from Piezoelectric pickup.

Wrap both wires the terminal lug, then, solder the joint.

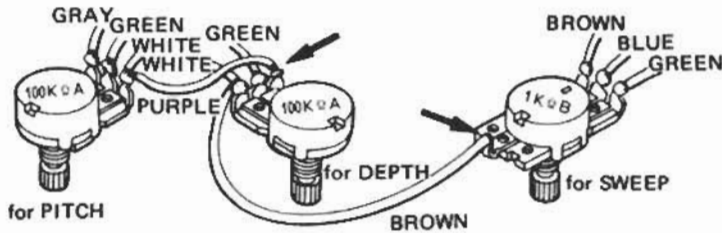

Solder to the blank terminal of DEPTH Control (100KΩA), the PURPLE wire from PITCH Control (100KΩA).

Solder to the blank terminal of SWEEP Control (1KΩB), the BROWN wire from DEPTH Control (100KΩA).

* The soldering works end here. Turn off the power to the soldering iron, then proceed to the next step.

8. The fit/detention key studs of all control pots are unnecessary in this assembly. Break them off with pliers, before proceeding to the next step. Be sure to break them flat from the bottom so that no protrusion is left to cause a slant mounting to the case.



9. Fix the controls to the case as follows — top row:
 100KΩA (Yellow, Blue, Orange) to RATE
 1MΩA (Yellow, White/Red) to DECAY
 100KΩA (Gray, Orange, White/Purple) to SENS

Use the specially made hexagonal wrench to tighten the washers and nuts. — second row:

100KΩA (Purple, Green, White/Brown) to DEPTH

1KΩB (Green, Blue, Brown) (Brown) to SWEEP

(The SWEEP should be fixed in a position 15° from the horizontal as illustrated.)

100KΩA (White/Purple, Green, Gray) to PITCH

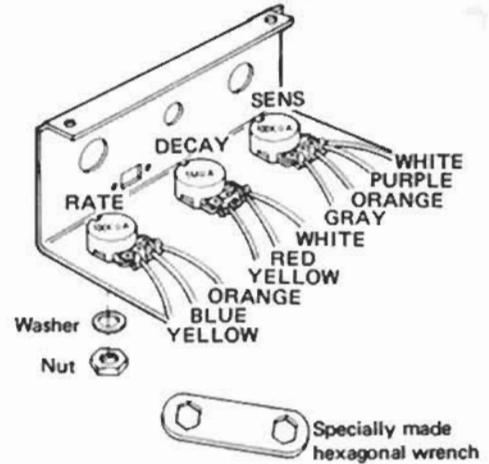

Rear view of the Case

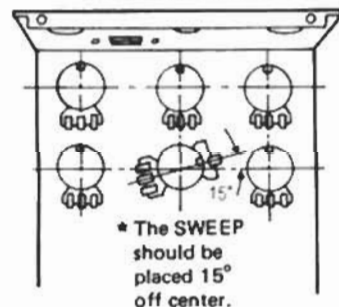

* The SWEEP should be placed 15° off center.

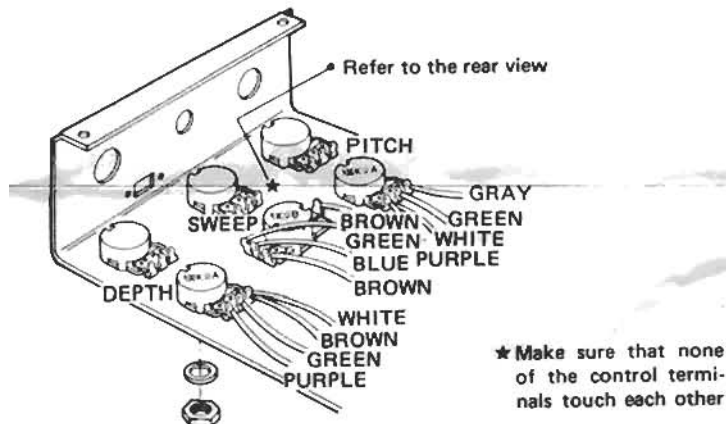

★ **CHECK:** With this step, all the wiring works are finished.
Make one more check to ascertain that the wiring is correct.

- 10.** Peel off one protective paper from the cushion ring exposing the adhesive attach it to the piezoelectric pickup. Remove the remaining protective paper from the other side; attach the piezoelectric pickup with the cushion ring to the case.

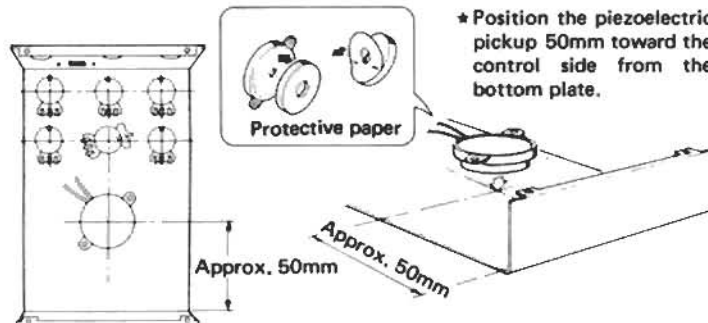

- 11.** Fix the slide switch to the case. This will become necessary later when you use it for modifications.

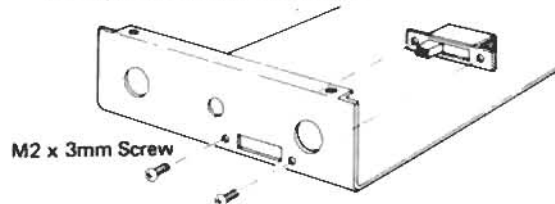

12. Fix the P.C.B. to the case. Put toothed washers over both jack heads on the P.C.B., then insert them into the holes in the case. Fasten the P.C.B. by tightening the jack heads with washers and nuts fitted to the other side.

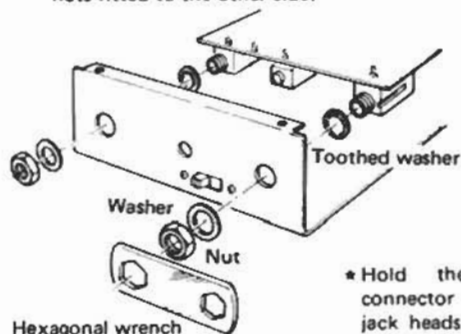

* Hold the battery snap connector away from the jack heads during this work.

13. Attach the self adhesive transparent insulator paper to the bottom plate after peeling the protective paper from the adhesive. Then, attach the sponge block to the insulator after peeling the protective paper from the adhesive.

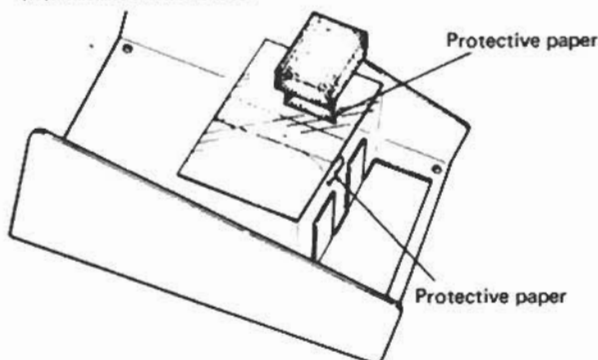

14. Attach another sponge block onto the case, in the same manner as 13.

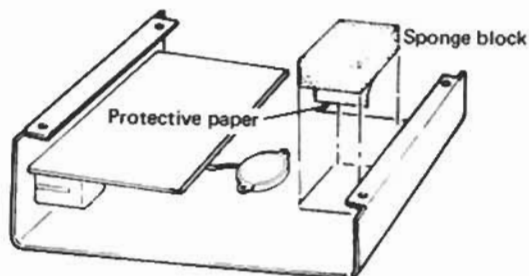

15. Assemble the bottom plate to the case, using 4 bind screws of M3 x 6mm. Attach the non-slip rubber sheets in two places after removing protective papers.

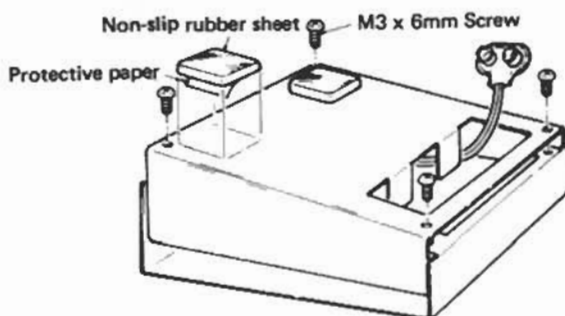

16. Insert a 006P battery and connect to the snap battery connector. Make sure that the battery polarity is correct.

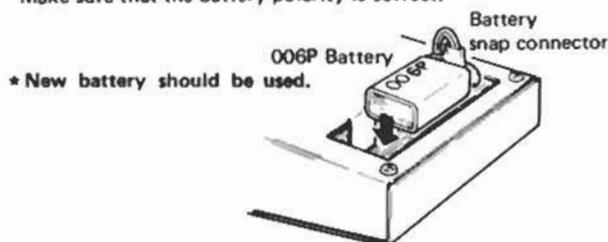

* New battery should be used.

17. Place the rubber cover over the battery inserting hole.

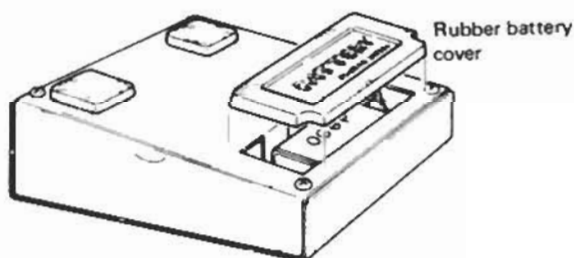

18. Now, fit the knobs to the controls, Firstly, turn the shaft fully CCW (Counter-clock wise), then insert the knob onto the the shaft so that the knob indicator is aligned to the (●) mark on the panel. With the SWEEP Control the shaft should be brought to the center click position, then insert the knob so that the indicator meets with the OFF mark.

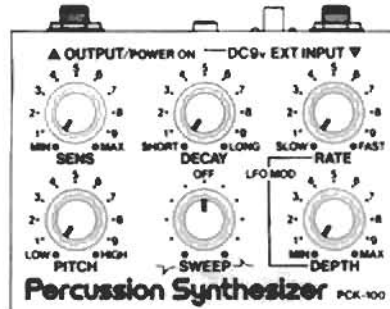
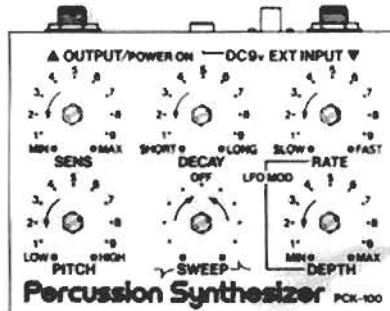

19. Attach the pad in position upon the case, removing firstly the self adhesive protective paper.

