

ANALOG SWITCHES

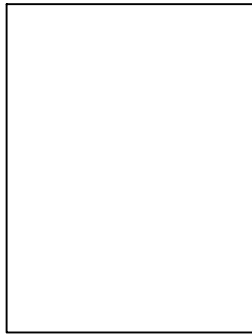

Analog Switches

AUX



misc

ONESHOT



oneshot

PATGEN

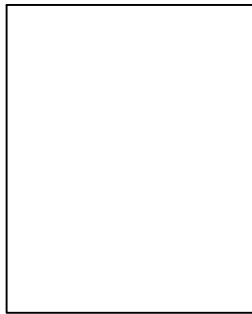

pattern Generator

SEQUENTIALSWITCH

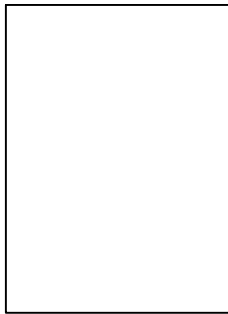

SequentialSwitch

TRANSPOSER

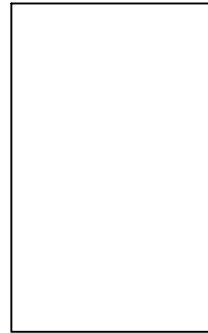

transposer

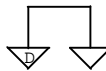

Title		
MIKADO ANALOG SEQUENCER-BOARD 3		
Size	Document Number	Rev
A	100-1014	A
Date:	Sunday, April 21, 2002	Sheet 1 of 8

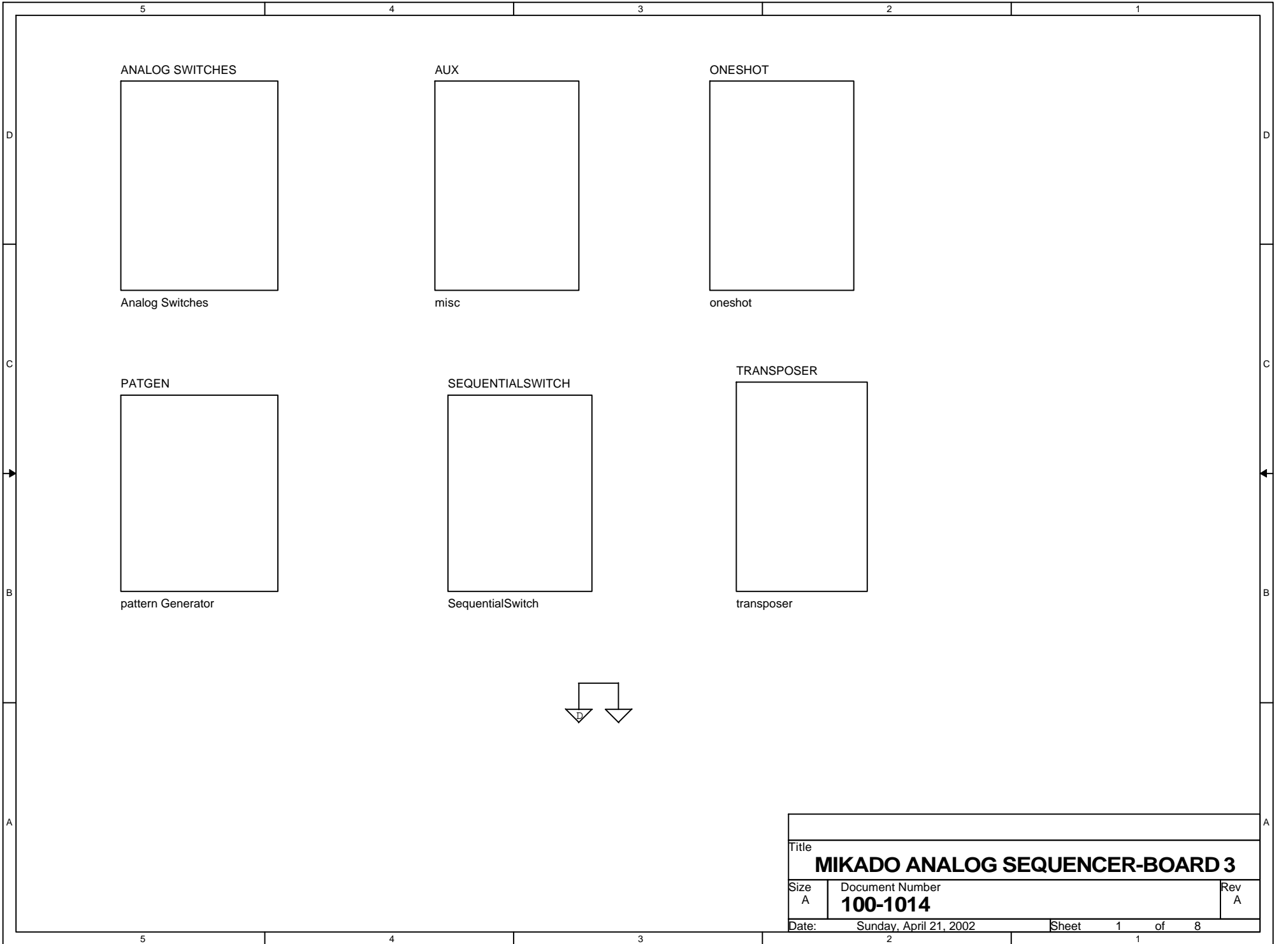

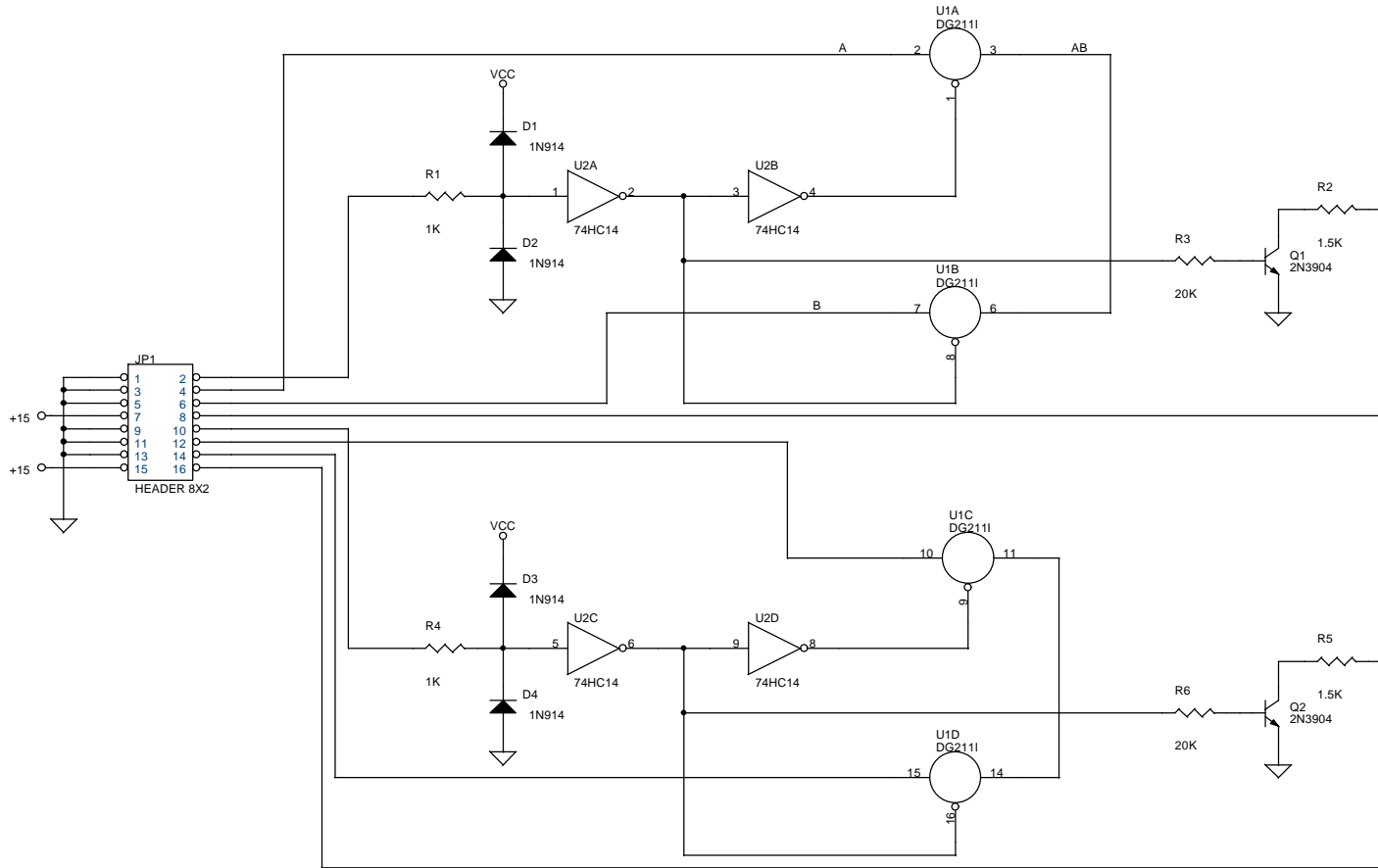

Title		
ANALOG SWITCHES		
Size	Document Number	Rev
	100-1014	A
Date:	Sunday, April 21, 2002	Sheet 2 of 8

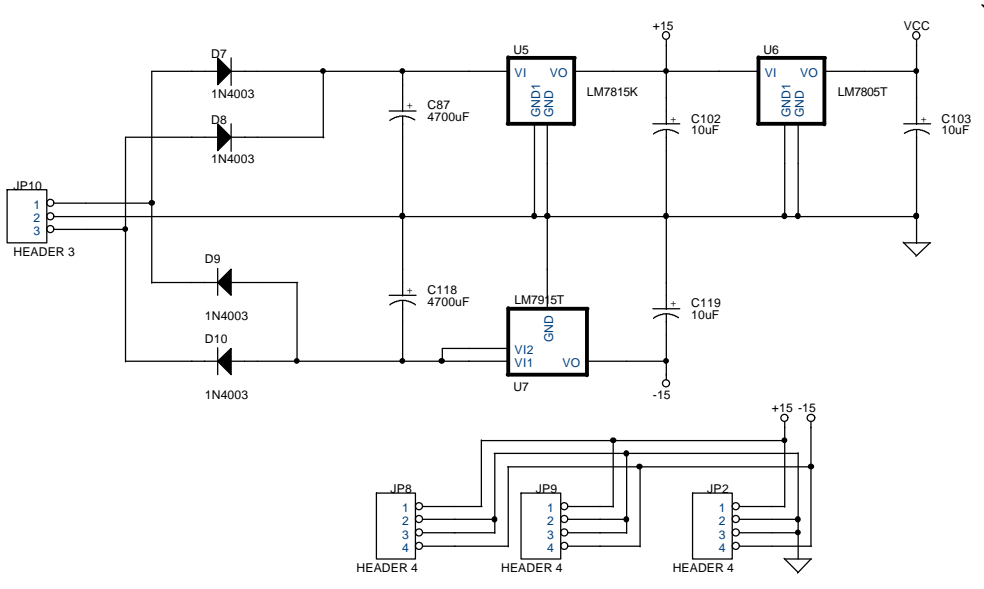
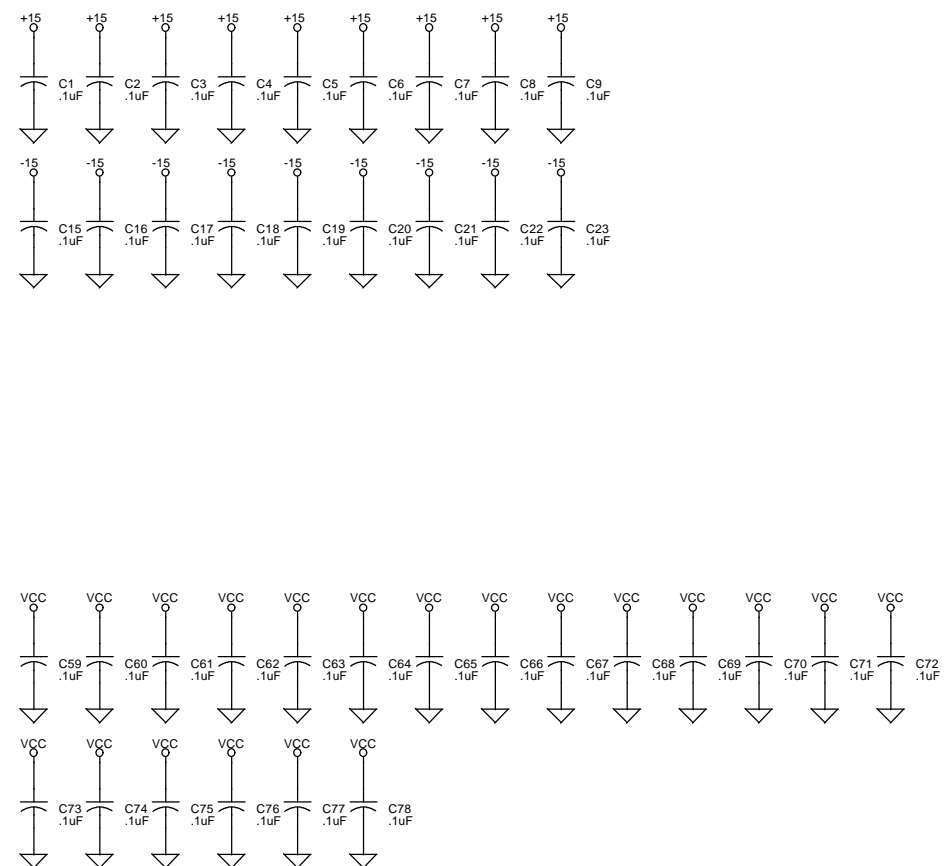
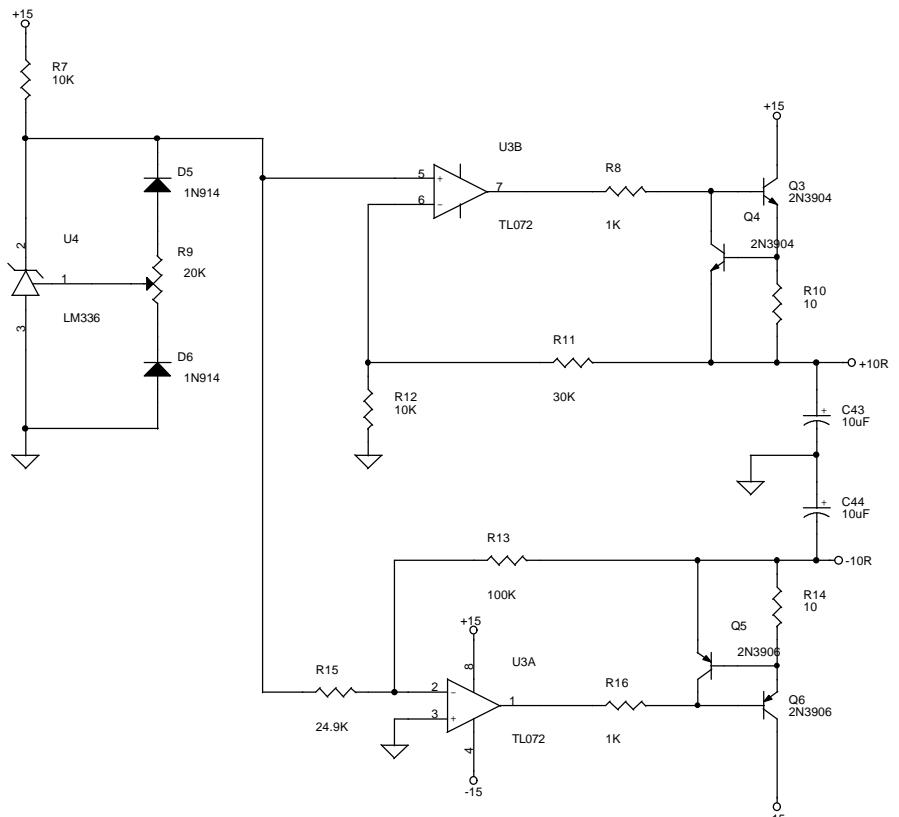

Title		
POWER SUPPLY/REFERENCES		
Size	Document Number	Rev
	100-1014	A
Date:	Sunday, April 21, 2002	Sheet 3 of 8

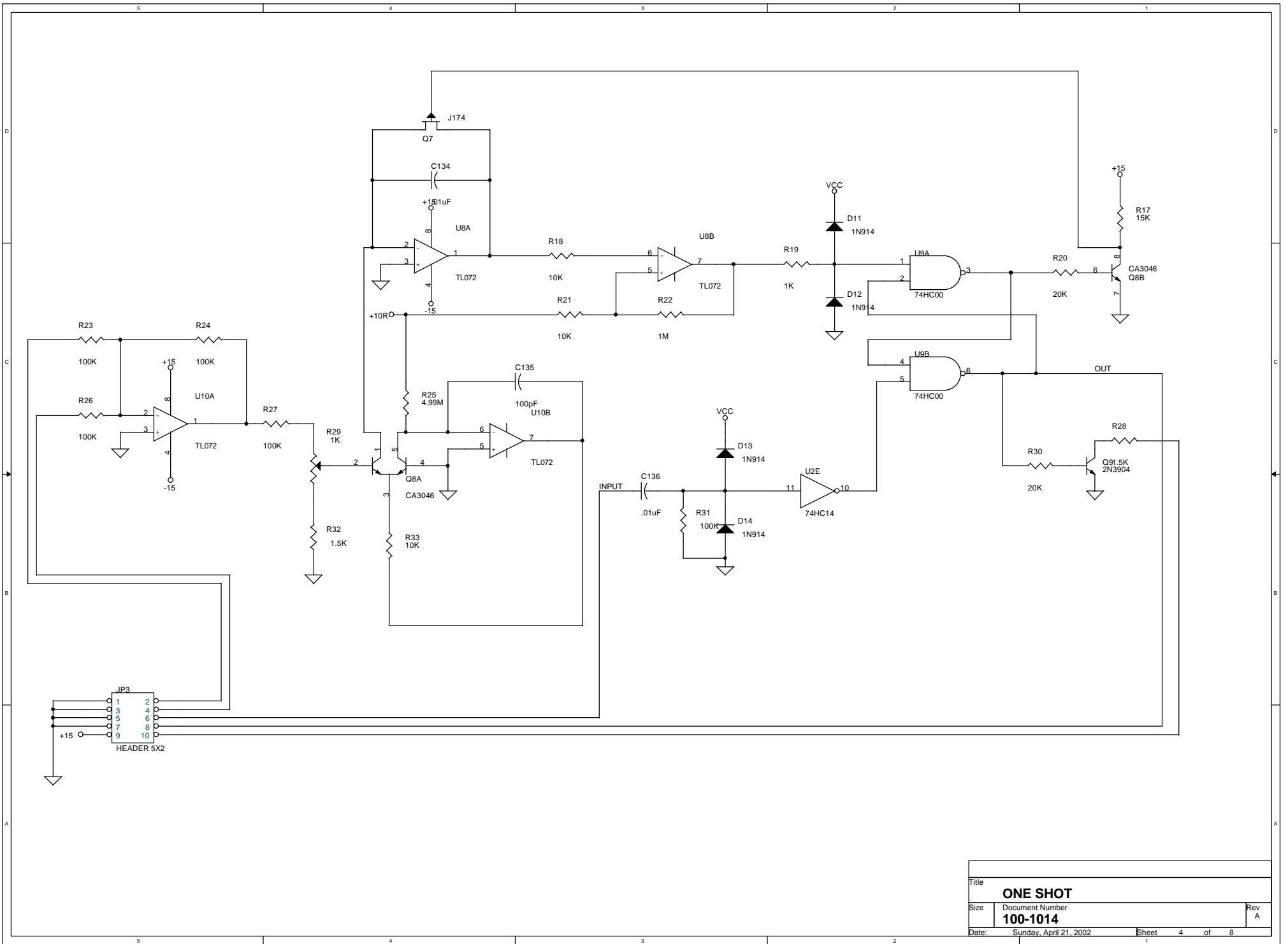

Title		
ONE SHOT		
Size	Document Number	Rev
	100-1014	A
Date:	Sunday, April 21, 2002	Sheet 4 of 8

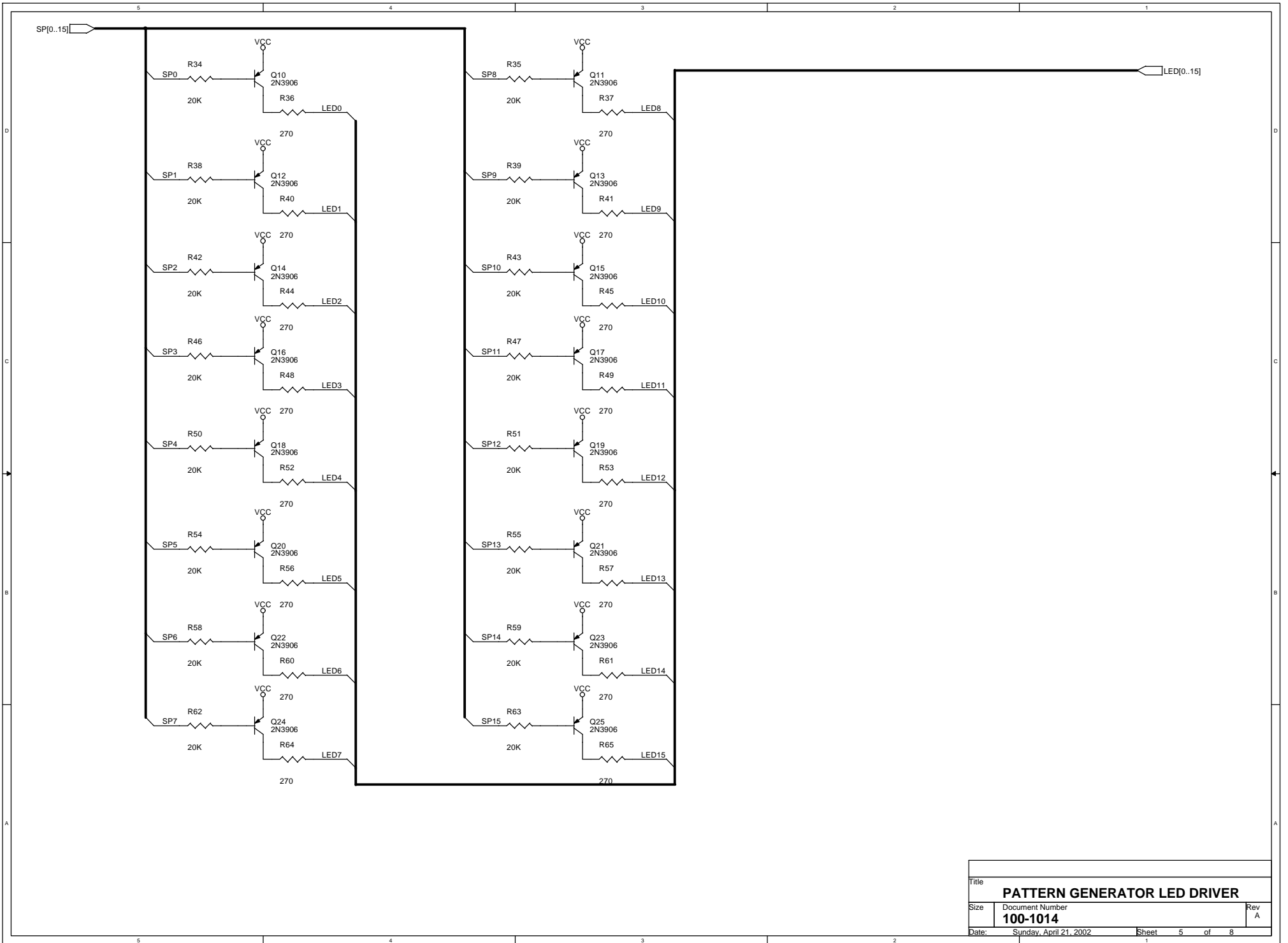

Title		
PATTERN GENERATOR LED DRIVER		
Size	Document Number	Rev
	100-1014	A
Date:	Sunday, April 21, 2002	Sheet 5 of 8

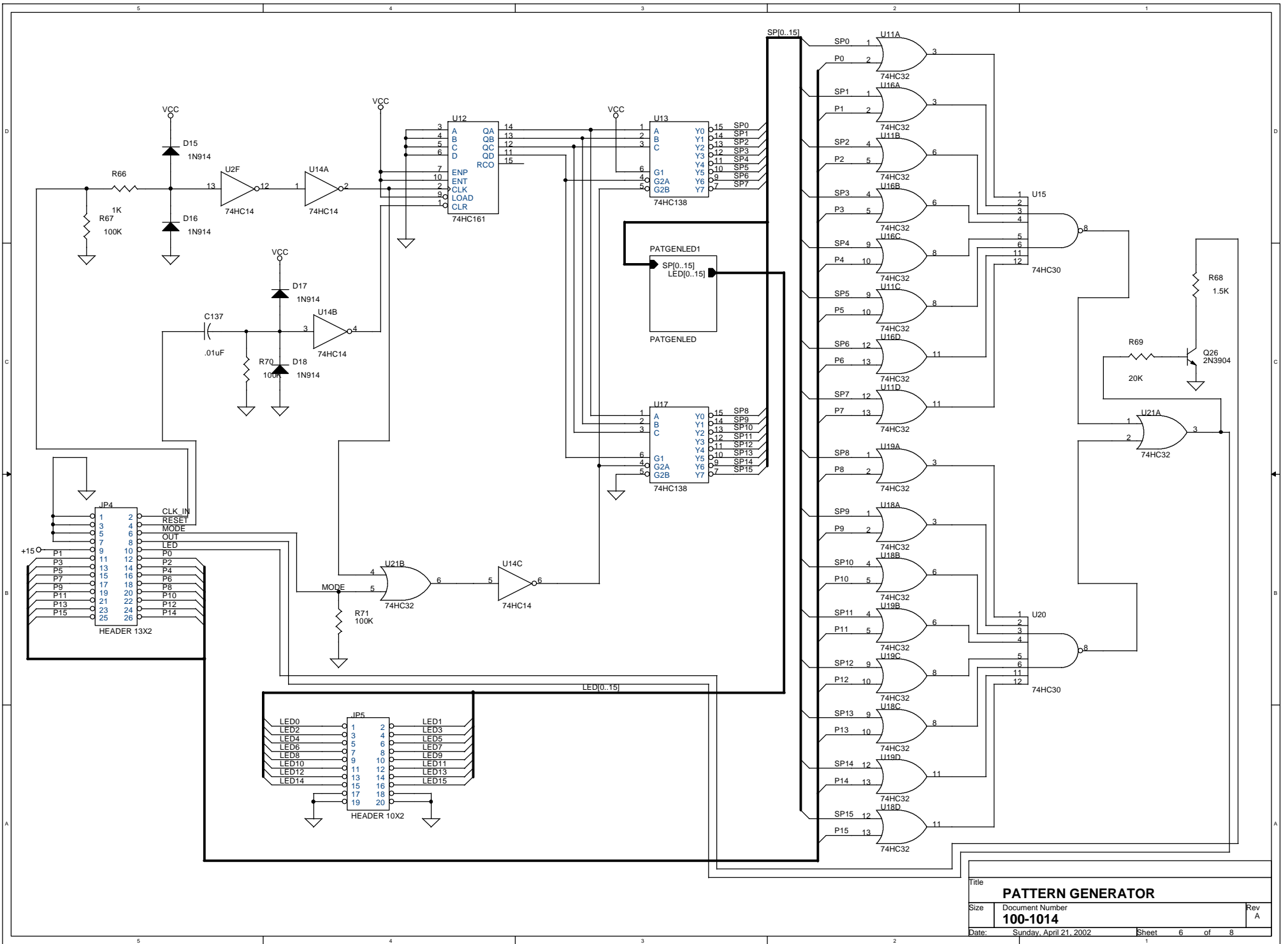

Title		
PATTERN GENERATOR		
Size	Document Number	Rev
	100-1014	A
Date:	Sunday, April 21, 2002	Sheet 6 of 8

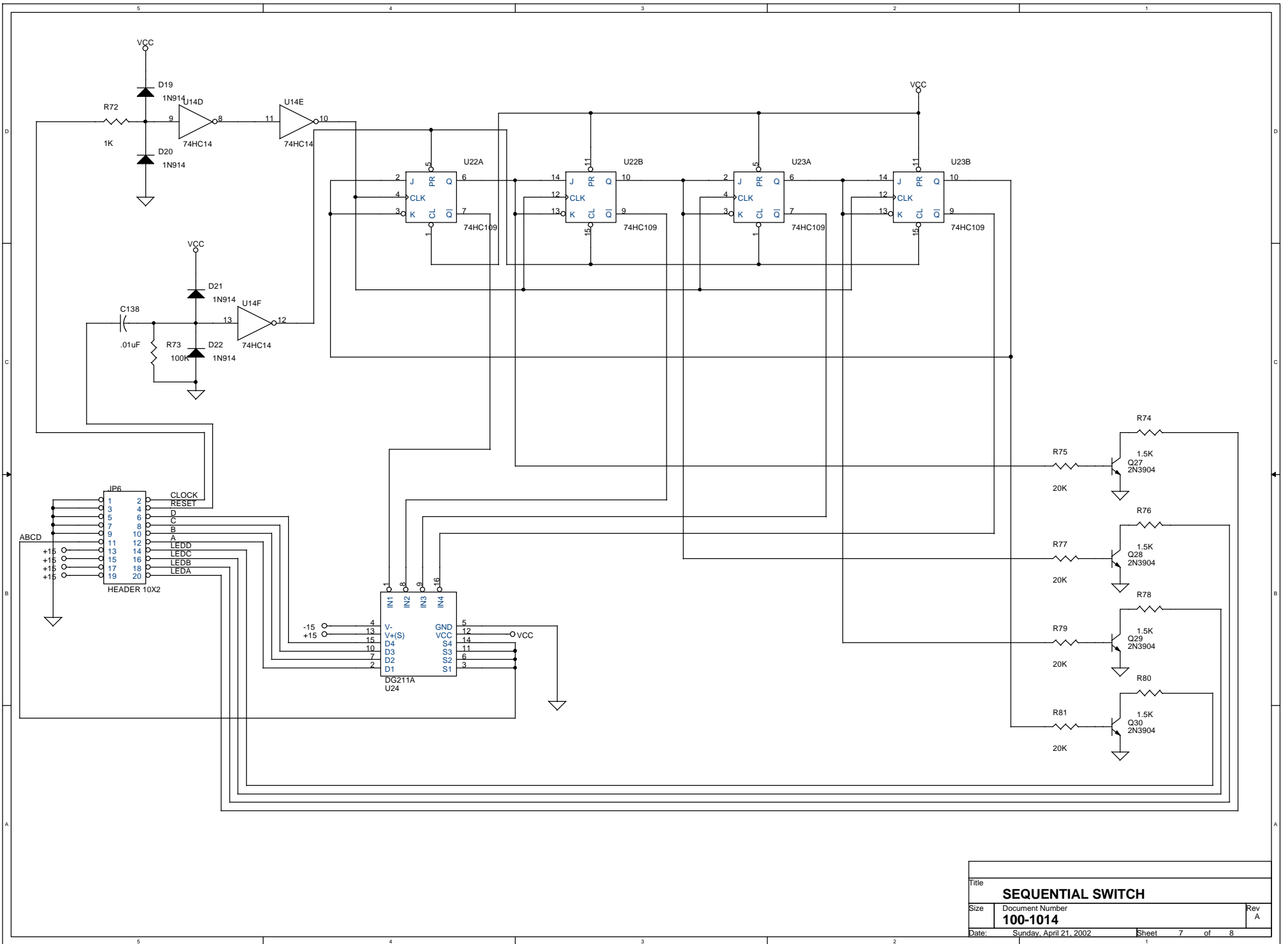

Title		
SEQUENTIAL SWITCH		
Size	Document Number	Rev
	100-1014	A
Date:	Sunday, April 21, 2002	Sheet 7 of 8

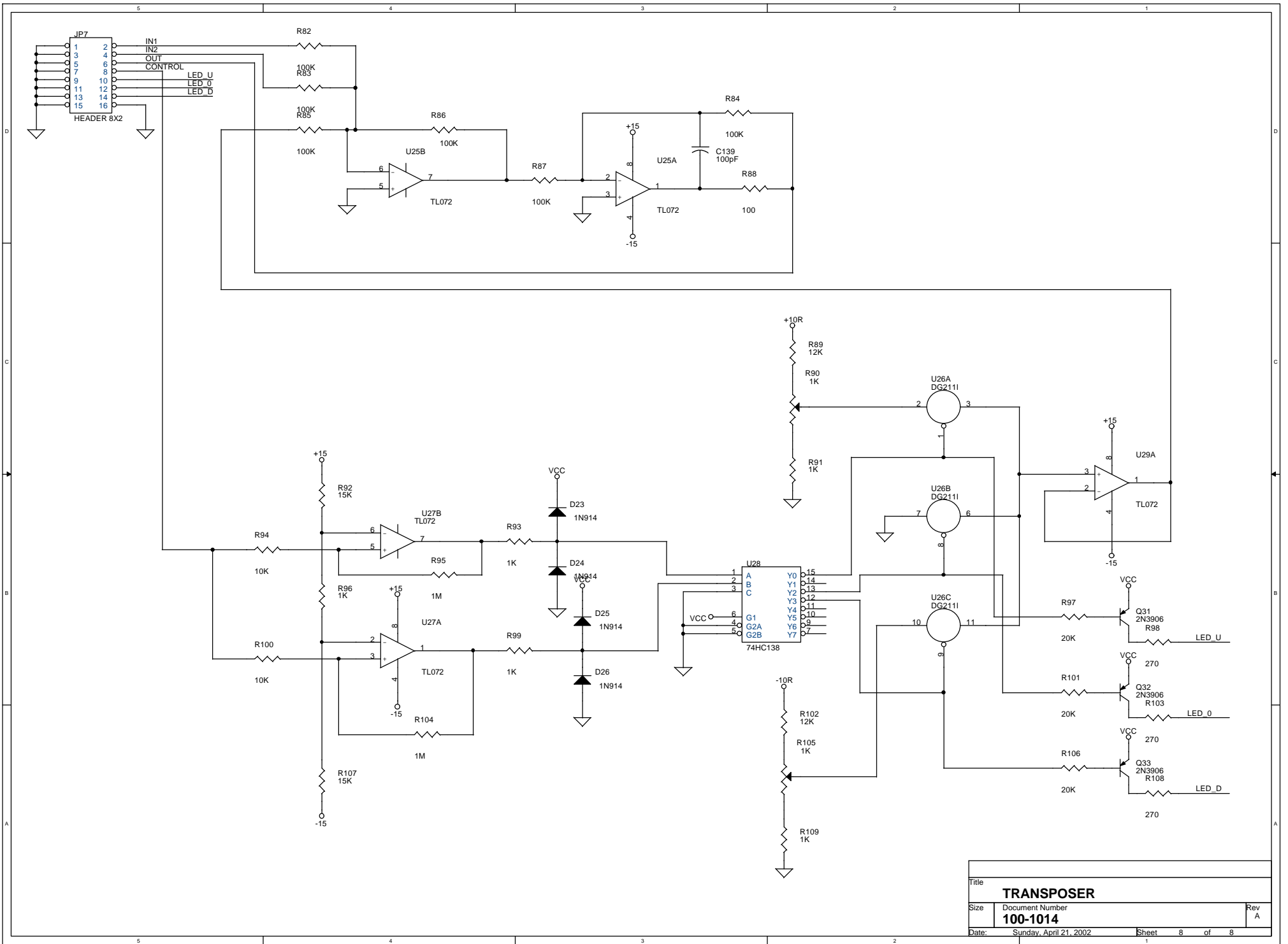

Title		
TRANSPOSER		
Size	Document Number	Rev
	100-1014	A
Date:	Sunday, April 21, 2002	Sheet 8 of 8