

HI-FI ACCESSORY

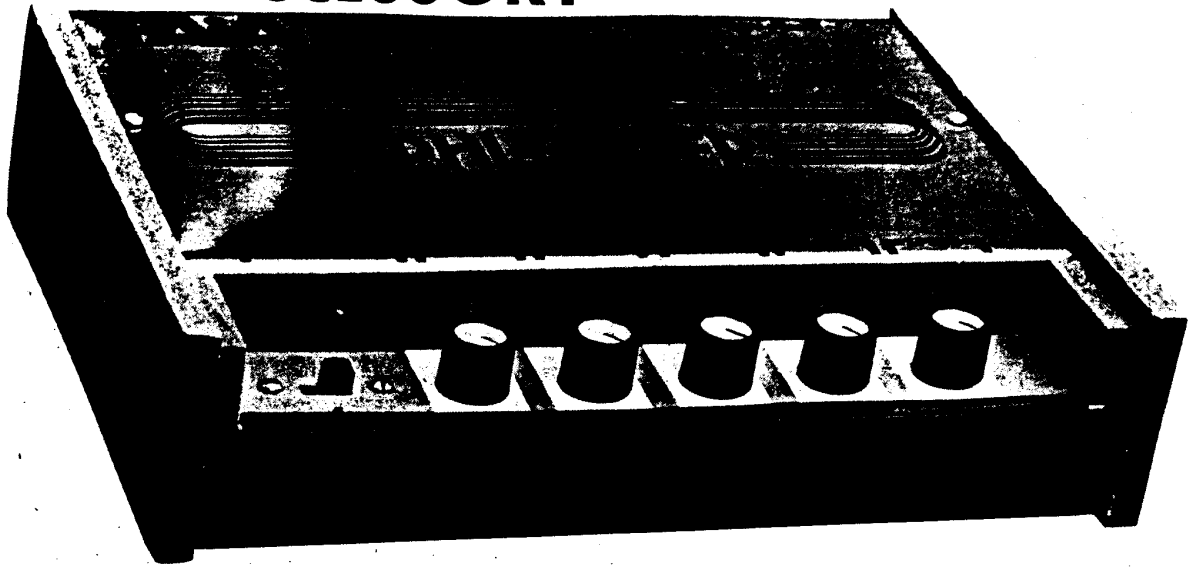

Build The PHLANGER for Dramatic Music Effects

Built around an analog delay line, this device connects easily to your hi-fi system to produce dramatic special effects

PHLANGING CAN MAKE YOUR HEAD spin: the effect can gently roll and sway, or it can seem to turn your whole mind inside out. Phlanging was discovered accidentally in 1958 by recording producer Phil Spector while recording "The Big Hurt." Thinking the vocal part was weak, Spector instructed his engineer to make two tapes and play them back simultaneously to achieve a voice-doubling effect. The dramatic "swooshing" effect that resulted was immediately recognized as a hit sound, and the record indeed received considerable attention.

After its initial success, many musicians and producers wanted to use the phlanging effect in recordings, but the technique of producing small controlled variations of tape recorder playback speed was time-consuming and cumbersome. Then in the 1970's, operational amplifiers and active filters were developed to produce this type of sound in a low-cost unit called a phase shifter. Phase shifters became a craze with musicians, but the octavely related cancellation frequencies of the all-pass networks used in phase shifters provide a much more bland sound than the harmonically related

notches of true time-delay phlanging. Now that charge-coupled technology has come of age, we have bucket-brigade analog delay lines that allow true phlanging.

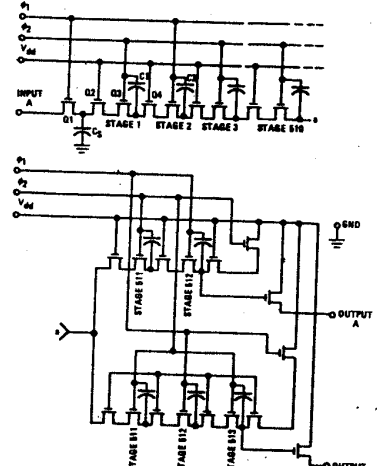

FIG. 1—ANALOG DELAY LINE uses capacitors to store analog voltages.

How it works

The most important component in the phlanger is the *Reticon SAD-1024* analog delay line made by Reticon Corp., 910 Benicia Rd., Sunnyvale, CA 94086. This new and special IC (See *IC Application of the Month*, in the April 1977 issue) uses N-channel technology to substantially improve both quality and ease of operation. The *SAD-1024* contains MOS transistors and capacitors in two identical arrays, one of which is shown in Fig. 1. The input accepts a maximum signal swing of 0.5-volts peak-to-peak, riding a bias that is 40% of the supply potential. The supply V_{dd} can range from 4 volts to 15 volts, with 9 volts to 15 volts providing the best specifications. The ϕ_1 and ϕ_2 are inputs for the biphasic high-frequency clock. These signals must switch between V_{dd} and ground, and be complementary with minimum overlap. When ϕ_1 is high, the input signal is gated through Q1 to input capacitor C₁ (see Fig. 1). At the next clock transition, C₁ is isolated and the last voltage applied to C₁ is held. As ϕ_1 goes low, ϕ_2 goes high allowing the charge on C₁ to be gated to storage capacitor C₂.

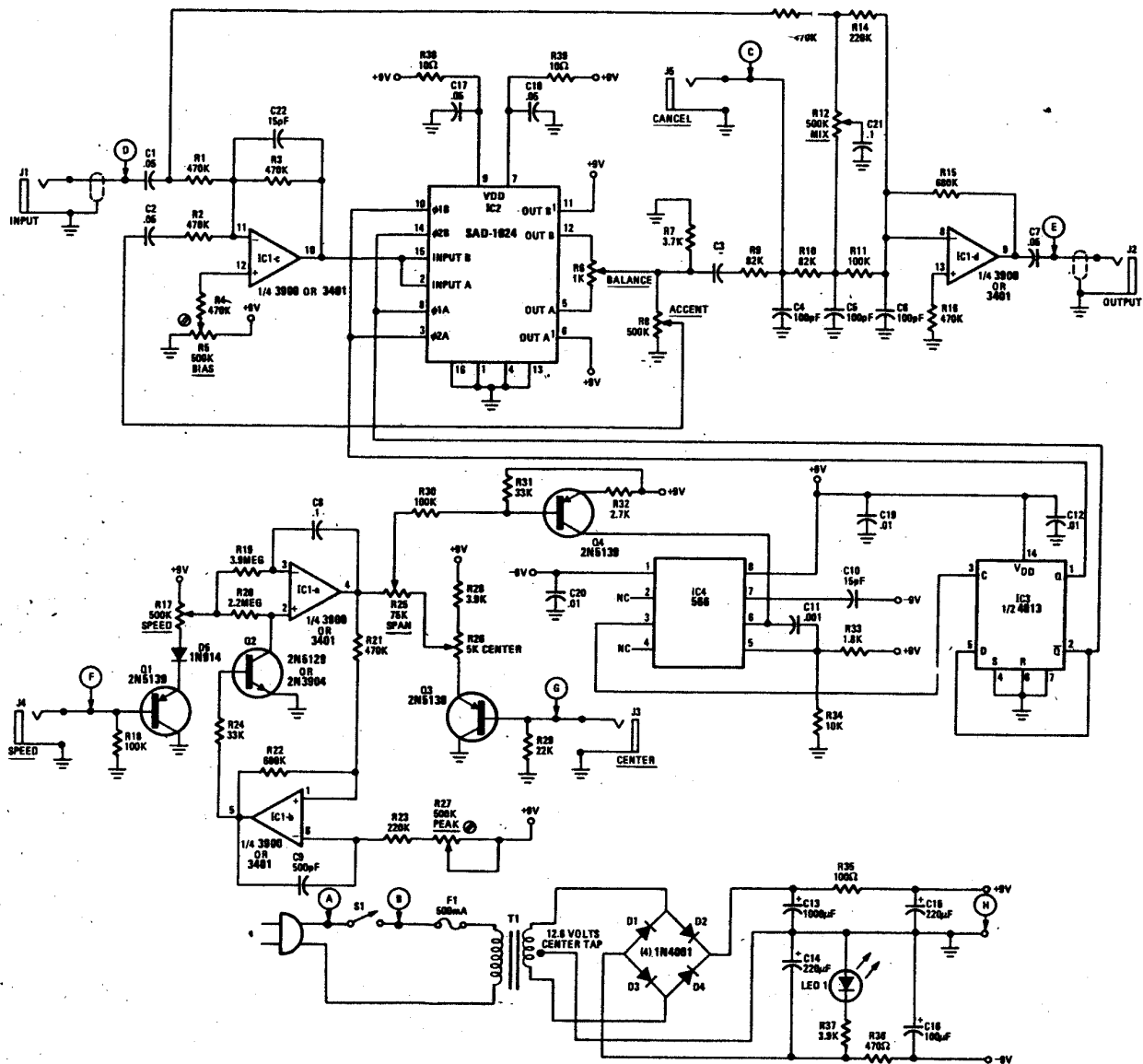

FIG. 2—PHLANGER uses an analog delay line to add "swooshing" effect to music.

PARTS LIST

All resistors 1/2 watt, 5% unless otherwise noted.

- R1-R4, R13, R14, R21—470,000 ohms
- R5, R27—500,000-ohm, linear PC-mount trimmer
- R6—1000-ohm, linear PC-mount trimmer
- R7, R32—2700 ohms
- R8, R12, R17—500,000-ohm linear potentiometer
- R9, R10—82,000 ohms
- R11, R18, R30—100,000 ohms
- R14, R23—220,000 ohms
- R15, R22—680,000 ohms
- R19—3.9 megohms
- R20—2.2 megohms
- R24, R31—33,000 ohms
- R25—75,000-ohm linear potentiometer
- R26—5000-ohm linear potentiometer
- R28, R37—3900 ohms
- R29—22,000 ohms
- R33—1800 ohms
- R35—100 ohms

- R38—470 ohms
- R38, R39—10 ohms
- C1-C3, C7, C17, C18—0.05 µF, ceramic disc
- C4-C8—100 pF, ceramic disc
- C8, C21—0.1 µF, Mylar
- C9—500 pF, ceramic disc
- C10, C22—15 pF, ceramic disc
- C11—0.001 µF, ceramic disc
- C12, C19, C20—0.01 µF, ceramic disc
- C13—1000 µF, 10 volt, electrolytic
- C14, C15—250 µF, 10 volt, electrolytic
- C16—100 µF, 10 volt, electrolytic
- D1-D4—1N4001 diode
- D5—1N914 or 1N4148 diode
- LED1—MLS 750
- Q1, Q3, Q4—2N5139 transistor
- Q2—2N5129 or 2N3904 transistor
- IC1—LM3900 or CA3401, quad Norton amp
- IC2—SAD-1024 analog delay line (Reticon)

- IC3—4013-type dual-D flip-flop
 - IC4—566-type VCO
 - F1—500-mA fuse, with surface mount holder
 - J1-J5—1/2-inch phone jacks
 - S1—SPST slide switch
 - T1—12.6 volt, center-tapped, 300-mA power transformer
 - MISC.—Hookup wire, line cord, 16-pin IC socket for IC2, knobs, case and hardware.
- The following parts are available from Pala Electronics, Inc., Box 14359, Oklahoma City, OK 73114.
- Etched, drilled and punched PC board, No. 1500PC, \$9 postpaid.
- Complete kit of parts including PC board, case and step-by-step instructions, No. 1500, \$59.95 plus 4-lb. shipping charge.
- Oklahoma residents add state and local taxes as applicable.

On the next clock transition, gating transistor Q3 is disabled, and Q4 is enabled to allow the charge in C1 to pass to the next stage. While ϕ_1 is again high, another input sample is taken. The discrete voltage levels continue to be clocked through the circuitry until, 512 clock half-cycles later, the original input voltage appears at output A. This same voltage appears also at output A' during the next, or 513th, clock period. Mixing these two outputs allows a more continuous output waveform to be generated, and also provides a means of improved suppression of clocking glitches.

The overall time delay generated by this circuit can be calculated from: $T_d = N/(2 F_c)$, where N is the number of shift register stages (512 in this case), and F_c represents the clock frequency at ϕ_1 and ϕ_2 . Output filtering should be used to remove any residual clock signals that are superimposed on the output and to smooth the sampled stair-step signal into

a duplicate of the original input.

Consideration must also be given to the number of samples required per input waveform period to accurately reproduce the waveform. When the sampling frequency is greater than 10 times the input frequency, oversampling occurs. However, higher sample rates yield higher reproduction accuracy. Critical sampling occurs when the input frequency is one-half the clock frequency, and this is the maximum limit to which the system should be pushed for accurate audio reproduction.

The schematic for the full phlanger is shown in Fig. 2. The input signal is buffered by IC1-c. Bias trimmer R5 adjusts the DC output to 40% of the supply voltage to provide minimum clipping of the signal as it enters the delay circuit. The signal is fed simultaneously to both delay line inputs of IC2. Note that the clock signals to each delay line are reversed so that ϕ_1 for one section is

ϕ_2 for the other. This operation, known as parallel multiplexing, causes each delay line to alternately sample the input signal. Thus, twice as many samples are provided for a given clock frequency, and reproduction accuracy is increased at the output. One output from each delay line are mixed together at BALANCE control R6, while unused outputs are tied to the supply voltage. The ACCENT control R8 feeds a portion of the delayed signal back to the input for regeneration. Low-pass filters R9-C4, R10-C5 and R11-C6 eliminate the remaining clock signal and smooth the sampled waveform into a more linear duplicate of the original. The MIXING control R12 allows selection of the normal input signal, the delayed signal or any blend of the two. The mixed signal is amplified by IC1-d to provide unity gain from the input to the output of the phlanger.

The remaining two sections of IC1 form the low-frequency triangle oscillator used to sweep the phlanger effect. The slope of integrator IC1-a is voltage-controlled. The control voltage is supplied by SPEED control R17 or remote SPEED input J4. Schmitt trigger IC1-a switches the integrator between a positive or negative slope. A fine adjustment of the triangle output amplitude of IC1-a is provided by PEAK control R27. This allows for optimum compatibility with following circuitry. The amount of triangle amplitude used to modulate the high-frequency clock is selected by SPAN control R25. As the voltage from the SPAN control is decreased, more of the fixed DC voltage from CENTER control R26 is used to set the clock to a fixed frequency.

With minimum SPAN and maximum

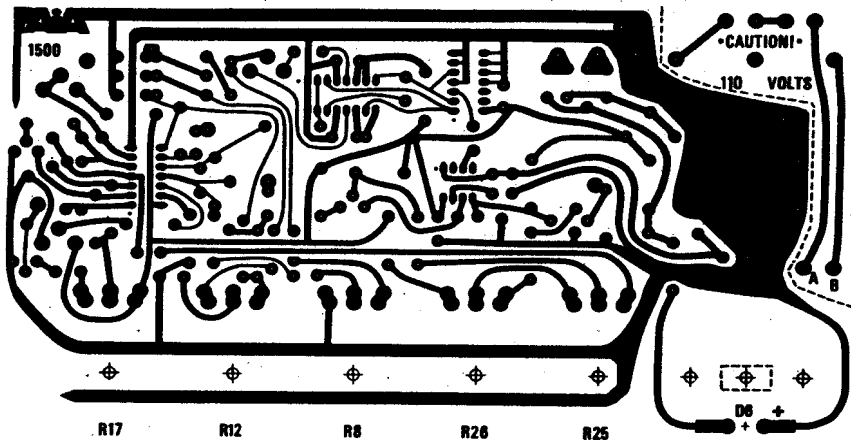

FIG. 3—FOIL PATTERN of single-sided PC board shown half-size.

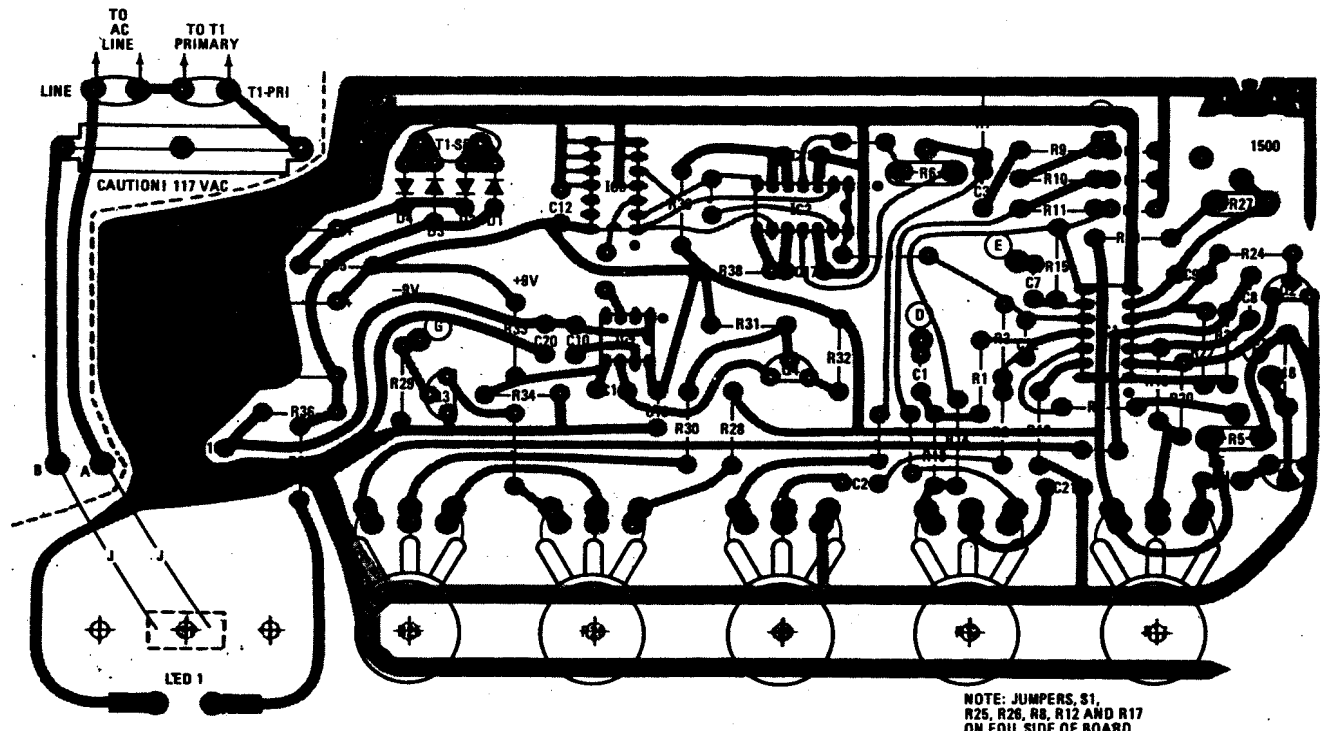

FIG. 4—COMPONENT PLACEMENT diagram.

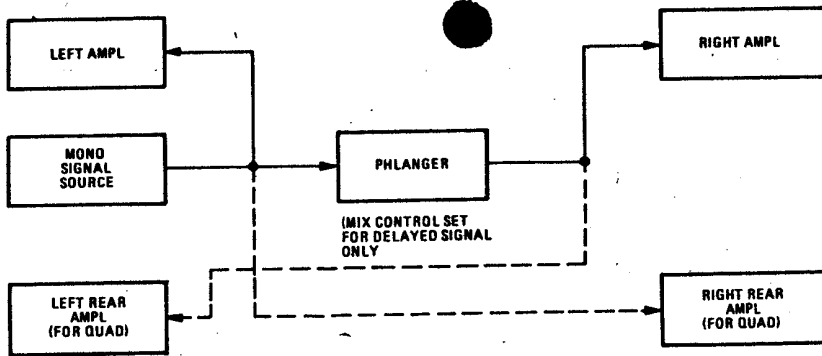

FIG. 5—STEREO EFFECT is produced from mono signal using this hook-up.

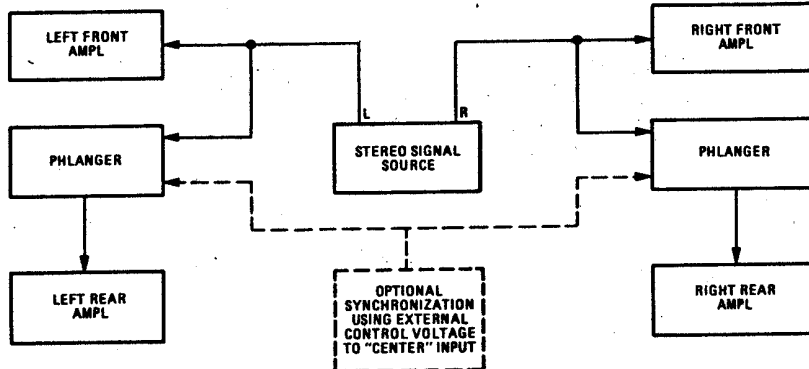

FIG. 6—QUADRIPHONIC EFFECT is produced from stereophonic source using two phlangers.

CENTER control settings, an external control voltage can be applied to J3 to modulate the clock frequency and, in turn, keep the phlanging effect. The mixed voltage from this control network is applied to current source Q4, which acts as a voltage-controlled timing resistor for high-frequency oscillator IC4. Timing capacitance is provided by C10. The squarewave output of IC4 switches between positive supply and half-supply, so a bipolar supply is used for this IC to make the squarewave switch between positive supply and ground. This signal is now directly compatible with the input of

D-type flip-flop IC3. This circuit divides the frequency in half, but, most important, it provides a set of complementary squarewaves that are very clean and with very little overlap. These signals are used to directly drive the clock inputs of the delay IC. The resulting clock frequency range is 30 kHz to 500 kHz. The power supply is a standard full-wave center-tapped bridge that provides a ± 9 -volt supply to the circuitry.

Construction

Assembly is straightforward, since all components are mounted on the circuit

board except for five jacks and the power transformer. The foil pattern for the circuit board is shown in Fig. 3 and the parts placement is shown in Fig. 4. Use only rosin core solder and a soldering iron (not a gun) with no more than a 35-watt power rating. When installing electrolytic capacitors, transistors, diodes and IC's, be sure to observe proper polarity. Note there are nine wire jumpers indicated by solid lines on the parts placement diagram (Fig. 4). Since the *Reticon SAD-1024* IC is expensive, use a socket for installation safety. The *SAD-1024* and the 4013 flip-flop are both CMOS units, and must be handled carefully. Do not wear synthetic clothing while handling these devices, and ground yourself and your soldering iron before handling or installing the units.

Power switch S1 is installed in the rectangular hole in the circuit board using No. 4-40 hardware. Use two 1½-inch long insulated wire jumpers to connect the switch lugs to points A and B on the foil side of the circuit board. Press power indicator LED1 into the hole below the power switch from the foil side of the board. Then solder the leads to the adjacent foil pads. Before mounting the five potentiometers, bend their solder lugs nearly 180° so that the lugs point toward the shaft rather than the rear of the potentiometer. Install one ¼-inch nut on the control bushing to act as a spacer, then mount the control as usual, making sure the altered solder lugs lie directly on top of the three oval pads on the foil side of the board. Flow solder into these connections. Mount the power transformer on the case with all five leads connecting to the rear of the circuit board. The letter-designated holes connect to the five jacks mounted on the case. Use coax cable for the input and output connections, with the shield connected to ground only at the jack. Connect point H to the common chassis ground of the five jacks. The remaining three connections can be made with single-conductor insulated wire.

Testing and calibration

Before applying power to the phlanger, double-check for cold solder joints, solder bridges and correct parts values and placement. Set the three trimmers to the midpoint of their rotation. Set all potentiometers fully counterclockwise, except CENTER control R26 which should be at maximum. Plug the line cord into a wall outlet and slide the power switch to the right. Power indicator LED1 should glow.

Apply a signal to input J1 with a maximum 0.5-volt amplitude peak-to-peak. Feed output J2 to an appropriate guitar amplifier or hi-fi system input. The normal signal should now be passing unaltered through the unit. Turn MIX control R12 fully clockwise. Adjust BIAS

continued on page 92

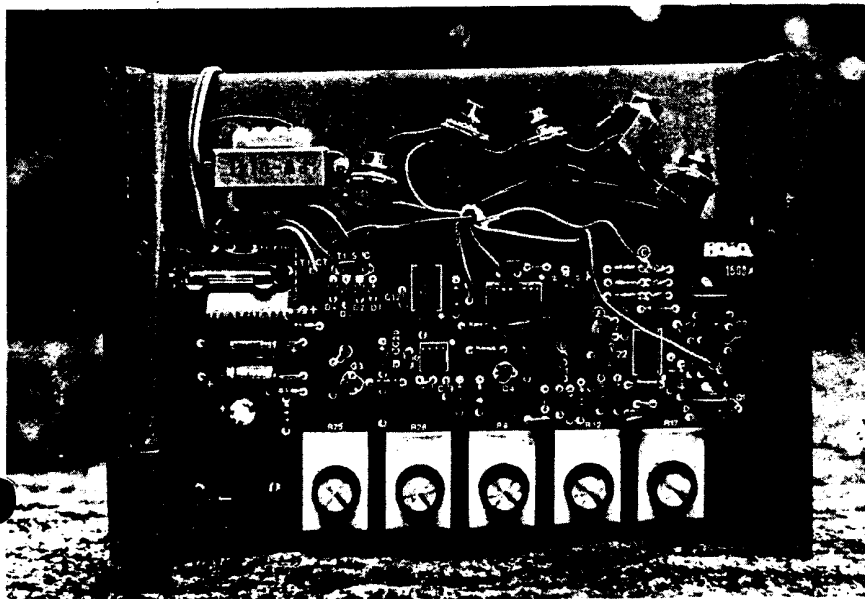

PHLANGER with top cover removed.



UNIVERSAL
TEST RIG

DOES IT
ALL

33KV



\$229.95

PJS-298
C.R.T. Included

- 33KV Leaded Glass CRT
- 40KV Meter
- Build-In Speaker
- Obsolete-Proof

The PJS-298 Universal Test Rig for tube and Solid State TVs designed for servicing high voltage chassis. Built-in speaker for convenient audio checking, 40KV-50Us sensitivity meter constant monitoring of the anode voltage. Up-dating is accomplished by means of plug-in modules. (Extension cables included).

FOR FAST TROUBLE SHOOTING

"FERRET" TV MINI-ANALYZER



\$99.95

SG-785

- VHF/UHF Subber
- I.F. - Video Trouble Shooter
- Convergence Generator
- Dots and Cross-Match Patterns

The "FERRET" is a multi-functional instrument for fast, efficient trouble-shooting and adjustment of all Color and B&W tvs. It is ideal for both shop and field work. (Cables included.)

TeleMatic

108-02 Ode Ave., Corona, N.Y. 11368

CIRCLE 72 ON FREE INFORMATION CARD

BUILD PHLANGER

continued from page 45

trimmer R5 until the signal is passed with minimum clipping (distortion).

If you have an oscilloscope, view the signal at the wiper of BALANCE trimmer R6. Set the scope controls so you can easily see the clocked audio signal. Two identical signals will seem to appear at different DC levels. Adjust BALANCE trimmer R6 until the two signals converge into one; this is the proper setting. If you do not have a scope, leave R6 at approximate midrotation and proceed with the calibration.

With the delay section properly trimmed, set MIX control R12 to the middle of its range. Decrease the CENTER control R26 setting and listen for the phlanger effect dropping through the audio spectrum. When the CENTER control is at minimum, advance ACCENT control R8 to maximum. You will hear the increased "hollowness" of the filter; and if you sweep CENTER control R26 through its range the phlanger effect becomes more pronounced. With the CENTER control at maximum, advance SPAN control R25 to maximum. The internal low-frequency oscillator will sweep the phlanger effect. At the bottom of each sweep you may hear a short "whEEP" or squeal. Adjust PEAK trimmer R27 until this sound is heard, and then return the trimmer to the point at which the squeals stop. As the internal oscillator sweeps the effect, advance SPEED control R17, which will increase the phlanger speed from approximately one sweep every five seconds to about one cycle per second.

With all calibration and checkout completed, all that remains is to mount the circuitry in a suitable enclosure. The phlanger is now ready to be used in its many applications. Here's a few of those applications.

Using the phlanger

A phlanger can reproduce the sound of tape-reel phlanger with an equal mix of normal and delayed signal. The ACCENT control should be set at minimum, and sweep SPEED and SPAN can be set as you wish. Increasing the ACCENT control will increase the "hollowness" of the sound and will add subjective depth to it. Experiment with the control settings. You'll find many of the effects quite interesting.

Many other effects can be obtained: For example, when the delay-circuit clock speed changes, the delay-line output provides a slight pitch shift. If the clock frequency continually increases, the audio signal will be sampled into the delay line at one frequency, but will be fed out at a higher frequency. Thus, the input frequency will be shifted up by an amount dependent on the rate of increase of clock frequency. In similar fashion, when the clock rate decreases, the input is shifted down in frequency. Using this phenomenon several unique effects can be achieved.

Vibrato effects can be generated with the MIX control set for a 100% delayed signal. The phlanger's triangle wave will then produce a squarewave modulation of pitch; or, by minimizing the SPAN control, an external sinewave can be fed into J3 for the familiar smooth vibrato. Most organs, guitars and synthesizers have provisions for vibrato generation. But imagine, if you will, providing vibrato on a recording of a grand piano, a choir or chimes. If you have recorded several basic instrument tracks and later decide you should have used vibrato on the sax solo, you can easily process that track through a modulated delay line during mixdown rather than going to the trouble of rerecording the entire track.

The phlanger can also be used to generate stereophonic or quadriphonic spatial effects with a monophonic signal. The original signal is fed to the phlanger input and to one of the amplifiers. The phlanger output is then fed to the remaining amplifier (see Fig. 5). The same control settings are used as for vibrato, except the sweep oscillator is set to a lower speed. When a harmonically complex signal is fed through this setup,

certain frequencies will be emitted from the two speakers in-phase. These frequencies will appear to have a source between the speakers. Other frequencies will have varying amounts of phase difference between the two speakers. This will cause a psychoacoustical phenomenon in which the sound seems to emanate from one side of the center. The actual phase relationship will determine whether the source is to the left or the right, and the amount of phase difference will determine how far off-center the sound is located. This dramatic effect sounds even better in a quadriphonic system where opposite corners are driven with the former stereo outputs (see Fig. 6). The sound appears to float and drift above your head. To generate a quadriphonic signal from a stereo source, use a separate phlanger for each side, with the normal signal feeding the front channels and the delay-modulated signals (phlanger outputs) feeding the rear channels. The internal-sweep oscillators can vary the delay times independently causing apparent random motion around the room; or an external modulation signal can be applied to the CENTER remote jack for a synchronized front-to-back motion on each side.

When the phlanger is interfaced with a voltage-controlled music synthesizer, astounding effects can be obtained using

sequencers, envelope generators or envelope followers as control voltage sources for the SPEED and CENTER inputs. To get a full rich sound process the output of one voltage-controlled oscillator through a phlanger. This will give the effect of two voltage-controlled oscillators being used simultaneously.

A phlanger used in conjunction with an organ provides an excellent simulation of large mechanical rotating speakers. With the SPAN, CENTER and ACCENT controls below midrange, the speed can be adjusted for the desired rotating effect, using an equal mix of normal and delayed signal.

Processing miked drums through the phlanger gives an effect of tuning the drum sounds. With the controls set for automatic sweep, the drums sound as if they are constantly being retuned as they are played. The increased tonality of the drums greatly enhances their presence and solo potentials.

A phlanger that has controls for so many sections of the circuitry need not be limited to music processing. For example, you can add delayed triggering to a scope's horizontal-sweep sync circuit or a voice-operated switch to a transmitter that won't chop off the beginning of the message.

R-E

projection television

Convert color to Giant Screen with the

\$1.85

Projection TV Lens

FASTEST LENS SPEED FOR BRILLIANCE & BRIGHTNESS
3 ELEMENTS; 6 OPTIC SURFACES
FOCAL LENGTH: 12-INCH (305mm)
MEASURES: 6.5" DIA. x 6.5" LENGTH

SPECIAL PRICE \$150

Write For Quantity Prices.

Send \$1 For Building Projection TV.

PROJECTAPIX, LTD.

300 WEST 53 STREET
NEW YORK, N.Y. 10019
TELEPHONES: (212) 765-7869

CIRCLE 73 ON FREE INFORMATION CARD

The J.M.J. DIGITAL DISPLAY BEZEL FOR APPEARANCE AND PERFORMANCE!

Now you can add a truly professional appearance to your digital projects and improve their performance as well... With the JMJ BEZEL. It will vastly improve the readability of the display and put a finishing touch on any front panel. And that's important, for obviously, the display is the most looked-at feature on any piece of digital equipment.

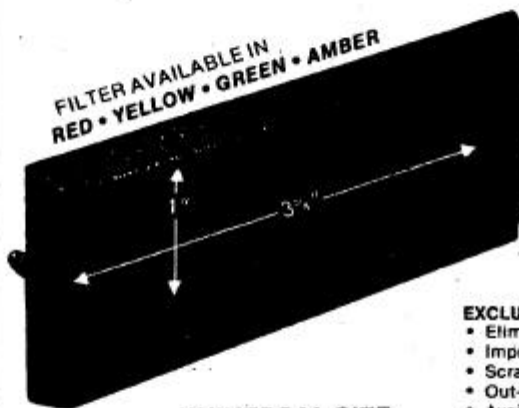

\$4.95 EACH

(Please order by color)

UNIVERSAL SIZE HANDLES MOST REQUIREMENTS

EXCLUSIVE CHROMAFILTER® SCREEN

- Eliminates glare and reflections
 - Improves contrast and readability
 - Scratch resistant—easily cleaned
 - Out-performs circular polarized types
 - Available in four colors
- DIE CAST METAL FRAME**
- Nonreflective black finish
 - Durable—heat resistant
 - Integral 6-32 mounting studs
 - No exposed hardware
 - Mounts in panels up to 3/16" thick
 - Includes all hardware and a special template for easy installation.

© Panelgraphic Corp., W. Caldwell, N.J.

DEALERS INQUIRIES INVITED

ATTENTION CLOCK BUILDERS

Adapters for mounting clock modules and clock displays directly to the JMJ-BEZEL. Assures perfect alignment and simplifies mounting (Please Order by Number).

\$.69 ea.

ADAPTER #1 (Fits the following)

National	Liton	Texas Inst.	Bowmar
MA 1001	LT 601	TIL 364	Opti-Stick
MA 1002	LT 442	thru	
NSB5917	LT 446	TIL 372	
NSB5921	LT 447		
NSB5922			

ADAPTER #2 (Fits the following)

National	Liton
MA 1010	LT 701
MA 1012	
MA 1013	

ADAPTER-3 (Universal Mount) For mounting any PC Board to the JMJ-BEZEL (Requires two mounting holes in PC Board).

TERMS: Minimum Order \$4.95
Add \$1.00 for Postage & Handling
N.J. Residents Add 5% Sales Tax
Send Check or M.O. — No COD's

NAME

ADDRESS

CITY

STATE

ZIP

— J.M.J. BEZELS at \$4.95 EA.
(COLOR: _____)

— ADAPTERS at \$.69 EA.
(NUMBER: _____)

POSTAGE & HANDLING

1.00

5% N.J. SALES TAX

AMOUNT ENCLOSED

J.M.J. TECHNICAL PRODUCTS, INC.
BOX 26, KENDALL PARK, N.J. 08824

CIRCLE 32 ON FREE INFORMATION CARD

OCTOBER 1977

93